



## **PDS Series**

### **Portable LCD Digital Storage Oscilloscope**

## **User Manual**

[WWW.OWON.COM.HK](http://WWW.OWON.COM.HK)

### **Nov. 2013 edition Ver1.4**

Copy Right in this Manual © Lilliput Company. All rights have been reserved.

The Lilliput's products are under the protection of the patent rights in America and other countries, including ones which have already obtained the patent rights and those which are applying for. The information in this manual will replace all that in the materials published originally.

The information in this manual was correct at the time of printing. However, OWON will continue to improve products and reserves the rights to changes specification at any time without notice.

OWON is the registered trademark of the Lilliput Company.

**Headquarter: Fujian Lilliput Optoelectronics Technology Co.,Ltd.:** The mansion of optoelectronics, 19 Heming Road, Lantian industrial zone, Zhangzhou, Fujian, China

**Tel:**+86-596-2130430

**Fax:**+86-596-2109272

**Web:** [www.owon.com.hk](http://www.owon.com.hk)

**Mail:** Business Consulting: [info@owon.com.hk](mailto:info@owon.com.hk)

Sale service: [service@owon.com.hk](mailto:service@owon.com.hk)

**Branch: Xiamen Lilliput Technology Co.,Ltd.:** the 5th floor, B Area, Chuangxin Mansion, Software Park, ZhenZhuWan, Huandao RD, Xiamen, Fujian, China

**Tel:**+86-592-2575666

**Fax:**+86-592-2575669

## General Warranty

The Lilliput warrants that the product will be free from defects in materials and workmanship for a period of three years from the date of purchase of the product by the original purchaser from the Lilliput company. And the warranty period of accessories such as probe, battery, adapter is one year. This warranty only applies to the original purchaser and is not transferable to the third party. If the product proves defective during the warranty period, Lilliput either will repair the defective product without charge for parts and labor, or will provide a replacement in exchange for the defective product. Parts, modules and replacement products used by Lilliput for warranty work may be new or reconditioned to like new performance. All replaced parts, modules and products become the property of Lilliput.

In order to obtain service under this warranty, Customer must notify Lilliput of the defect before the expiration of the warranty period. Customer shall be responsible for packaging and shipping the defective product to the service center designated by Lilliput, and with a copy of customer proof of purchase.

This warranty shall not apply to any defect, failure or damage caused by improper use or improper or inadequate maintenance and care. Lilliput shall not be obligated to furnish service under this warranty a) to repair damage resulting from attempts by personnel other than Lilliput representatives to install, repair or service the product; b) to repair damage resulting from improper use or connection to incompatible equipment; c) to repair any damage or malfunction caused by the use of non-Lilliput supplies; or d) to service a product that has been modified or integrated with other products when the effect of such modification or integration increases the time or difficulty of servicing the product.

Please contact the nearest Lilliput's Sales and Service Offices for services or a complete copy of the warranty statement.

**Excepting the after-sales services provided in this summary or the applicable warranty statements, Lilliput will not offer any guarantee for maintenance definitely declared or hinted, including but not limited to the implied guarantee for marketability and special-purpose acceptability. Lilliput should not take any responsibilities for any indirect, special or consequent damages.**

## Table of Contents

<i>General Safety Information</i> .....	4
<i>Safety Terms and Symbols</i> .....	5
<i>General features</i> .....	7
<i>Junior User's Guidebook</i> .....	8
<b>Introduction to the Front Panel and the User's Interface of the PDS series Oscilloscope</b> ....	9
<b>Check the Package Contents</b> .....	13
<b>To perform the Function Inspection</b> .....	14
<b>To perform the Probe Compensation</b> .....	16
<b>To set the Probe Attenuation Coefficient</b> .....	17
<b>To use the Probe Safely</b> .....	18
<b>To perform Self-calibration</b> .....	18
<b>Introduction to the Vertical System</b> .....	19
<b>Introduction to the Horizontal System</b> .....	20
<b>Introduction to the Trigger System</b> .....	21
<i>Advanced User's Guidebook</i> .....	22
<b>To set the Vertical System</b> .....	23
<b>Perform Mathematical Manipulation Function</b> .....	26
Using FFT function .....	26
<b>Application of VERTICAL POSITION and VOLTS/DIV Knobs</b> .....	30
<b>To set the Horizontal system</b> .....	31
<b>To set the Trigger System</b> .....	33
<b>Trigger Control</b> .....	34
<b>To operate the Function Menu</b> .....	39
<b>To perform Sampling Setup</b> .....	39

<b>To set the Display System.....</b>	<b>40</b>
<b>To Save and Recall a Waveform.....</b>	<b>42</b>
<b>To perform the Auxiliary System Function Setting.....</b>	<b>44</b>
<b>To perform the Automatic Measurement.....</b>	<b>46</b>
<b>To perform the Cursor Measurement.....</b>	<b>49</b>
<b>Use Autoscale .....</b>	<b>51</b>
<b>Use Executive controls .....</b>	<b>53</b>
<b><i>Quick Start Guide .....</i></b>	<b><i>54</i></b>
<b>Example 1: Measuring a Simple Signal.....</b>	<b>54</b>
<b>Example 2: Working out the Gain of the Amplifier in the Metering Circuit.....</b>	<b>55</b>
<b>Example 3: Capture the Single Signal .....</b>	<b>56</b>
<b>Example 4: Analyze the Details of a Signal.....</b>	<b>57</b>
<b>Example 5: Examine the Phase shift between two related signals .....</b>	<b>59</b>
<b>Example 6: Video Signal Trigger .....</b>	<b>60</b>
<b><i>Troubleshooting.....</i></b>	<b><i>61</i></b>
<b><i>Appendix A: Technical Specifications .....</i></b>	<b><i>62</i></b>
<b><i>Appendix B: Package Contents.....</i></b>	<b><i>67</i></b>
<b><i>Appendix C: Maintenance, Cleaning and Repairing.....</i></b>	<b><i>67</i></b>
<b><i>Appendix D: Battery Using Guide .....</i></b>	<b><i>68</i></b>

## General Safety Information

**Before any operations, please read the following safety precautions to avoid any possible bodily injury and prevent this product or any other products connected from damage. In order to avoid any contingent danger, this product is only used within the range specified.**

Only the qualified technicians can implement the maintenance.

**To avoid Fire or Personal Injury:**

- **Connect the probe correctly.** The grounding end of the probe corresponds to the grounding phase. Please don't connect the grounding end to the positive phase.
- **Use Proper Power Cord.** Use only the power cord supplied with the product and certified to use in your country.
- **Connect or Disconnect Correctly.** When the probe or test lead is connected to a voltage source, please do not connect and disconnect the probe or test lead at random.
- **Product Grounded.** This instrument is grounded through the power cord grounding conductor. To avoid electric shock, the grounding conductor must be grounded. The product must be grounded properly before any connection with its input or output terminal.

**When powered by AC power, it is not allowed to measure AC power source directly, because the testing ground and power cord ground conductor are connected together, otherwise, it will cause short circuit.**


**When powered by battery, the product must ground connection. To avoid electric shock, there must be a ground wire connect between ground and the ground port (on the back of product panel).**


- **Check all Terminal Ratings.** To avoid fire or shock hazard, check all ratings and markers of this product. Refer to the user's manual for more information about ratings before connecting to the instrument.
- **Do not operate without covers.** Do not operate the instrument with covers or panels removed.
- **Use Proper Fuse.** Use only the specified type and rating fuse for this instrument.
- **Avoid exposed circuit.** Do not touch exposed junctions and components when the instrument is powered.
- **Do not operate if in any doubt.** If you suspect damage occurs to the instrument, have it inspected by qualified service personnel before further operations.
- **Use your Oscilloscope in a well-ventilated area.** Make sure the instrument installed with proper ventilation, refer to the user manual for more details.
- **Do not operate in wet conditions.**
- **Do not operate in an explosive atmosphere.**
- **Keep product surfaces clean and dry.**

# Safety Terms and Symbols

## Safety Terms

**Terms in this manual.** The following terms may appear in this manual:

 **Warning:** Warning indicates the conditions or practices that could result in injury or loss of life.

 **Caution:** Caution indicates the conditions or practices that could result in damage to this product or other property.

**Terms on the product.** The following terms may appear on this product:

**Danger:** It indicates an injury or hazard may immediately happen.


**Warning:** It indicates an injury or hazard may be accessible potentially.

**Caution:** It indicates a potential damage to the instrument or other property might occur.


## Safety Symbols


**Symbols on the product.** The following symbol may appear on the product:

 Hazardous Voltage

 Refer to Manual

 Protective Earth Terminal

 Chassis Ground

 Test Ground

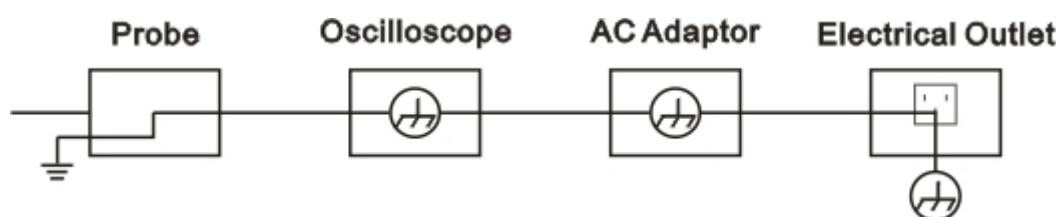
To avoid body damage and prevent product and connected equipment damage, carefully read the following safety information before using the test tool. This product can only be used in the specified applications.

 **Warning:**

The two channels of the oscilloscope are non-isolated electrically. The channels should adopt common basis during measuring. To prevent short circuits, the 2 probe ground must not be connected to 2 different non-isolated DC level.

 **Warning:**

The channels should adopt common basis during measuring. To prevent short circuits, the 2 probe ground must not be connected to 2 different non-isolated DC level. The diagram of the oscilloscope ground wire connection:



It is not allowed to measure AC power when charging the oscilloscope with adapter.

 **Warning:**

To avoid fire or electrical shock, when the oscilloscope input signal connected is more than 42V peak (30Vrms) or on circuits of more than 4800VA, please take note of below items:

- Only use accessory insulated voltage probes and test lead.
- Check the accessories such as probe before use and replace it if there are any damages.
- Remove probes, test leads and other accessories immediately after use.
- Remove USB cable which connects oscilloscope and computer.
- Do not apply input voltages above the rating of the instrument because the probe tip voltage will directly transmit to the oscilloscope. Use with caution when the probe is set as 1:1.
- Do not use exposed metal BNC or banana plug connectors.
- Do not insert metal objects into connectors.



## General features

<u>Model</u>	<u>Bandwidth</u>	<u>Sample Rate</u>
<u>PDS5022S/T</u>	<u>25MHz</u>	<u>100MS/s</u>
<u>PDS6042S</u>	<u>40MHz</u>	<u>250MS/s</u>
<u>PDS6062S</u>	<u>60MHz</u>	<u>250MS/s</u>

- Record length of 6,000 points for each channel;
- Reading-out with the cursor;
- Twenty automatic measurement functions;
- Autoscale function;
- Color liquid crystal display of high resolution and high contrast;
- Storage and recall waveforms;
- Automatic setting function provided capable of fast setting;
- Multiple-waveform calculation function;
- Built-in FFT function;
- Perform detecting the average and peak values of the waveform;
- Real-time Digital Oscilloscope;
- Multiple triggering ,including Edge, video and Alternating triggering;
- RS232 or USB communication ports for PC;
- Different continuous displaying time;
- Multiple language User interface.

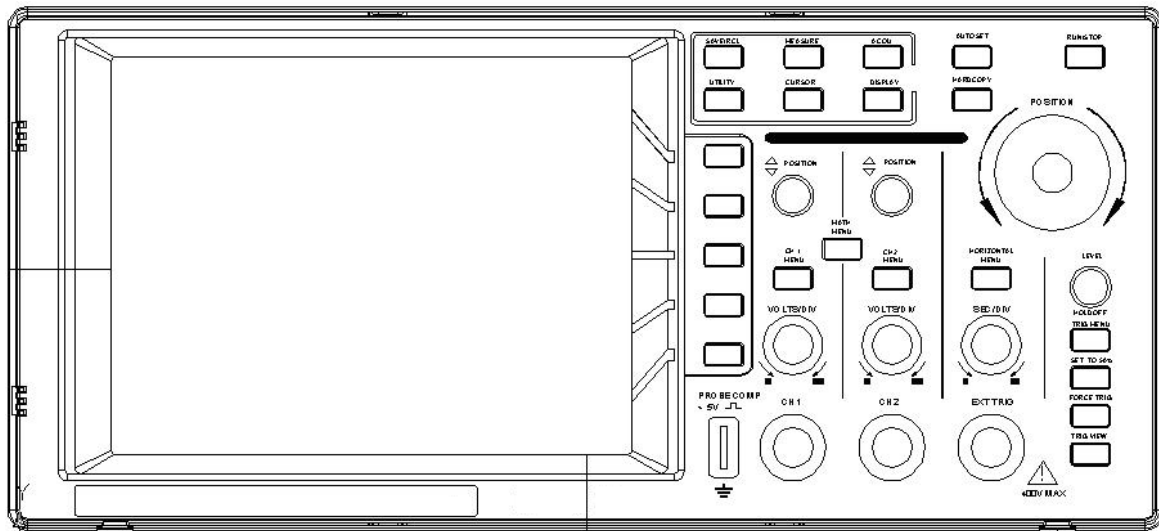
## Junior User's Guidebook

**This chapter deals with the following topics mainly:**

- Introduction to the front panel and the user's interface of the PDS series oscilloscope
- To perform the general inspection
- To perform the function inspection
- To perform the probe compensation
- To set the probe attenuation coefficient
- To use the probe safely
- To perform an self-calibration
- Introduction to the vertical system
- Introduction to the horizontal system
- Introduction to the trigger system

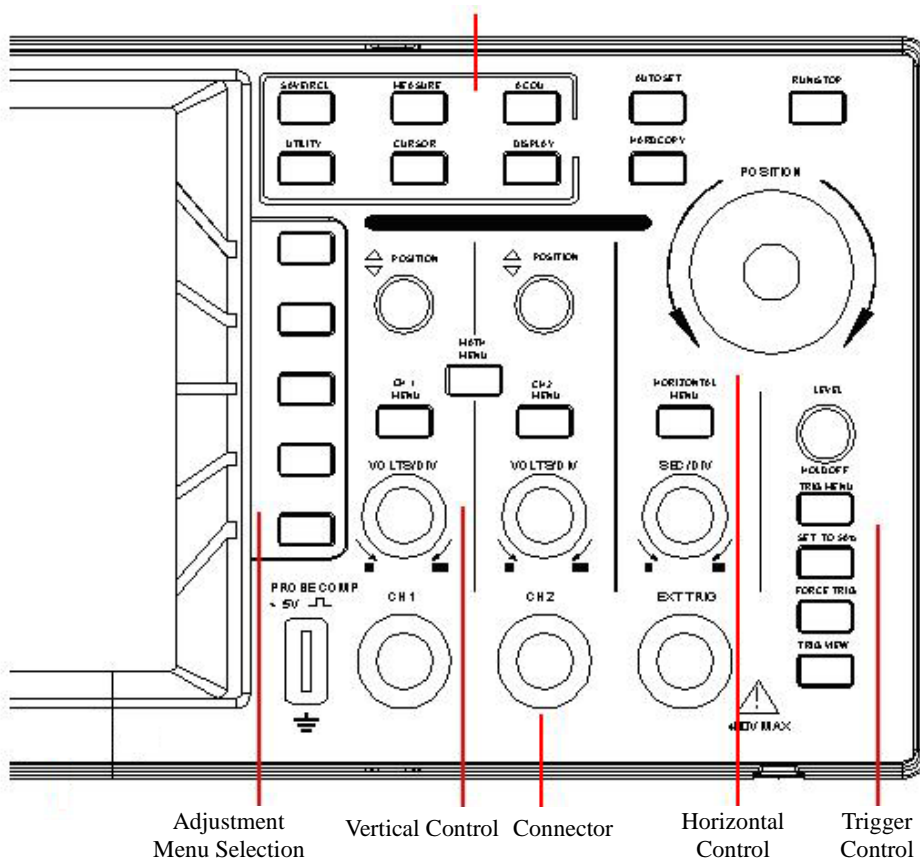
## **Introduction to the Front Panel and the User's Interface of the PDS series Oscilloscope**

When you get a new-type oscilloscope, you should get acquainted with its front panel at first and the PDS series digital storage oscilloscope is no exception. This chapter makes a simple description of the operation and function of the front panel of the PDS series oscilloscope, enabling you to be familiar with the use of the PDS series oscilloscope in the shortest time. The PDS series oscilloscope offers a simple front panel with distinct functions to users for their completing some basic operations, in which the knobs and function pushbuttons are included. The knobs have the functions similar to other oscilloscopes. The 5 buttons in the column on the right side of the display screen are menu selection buttons (defined as F1 to F5 from top to bottom respectively), through which, you can set the different options for the current menu. The other pushbuttons are function buttons, through which, you can enter different function menus or obtain a specific function application directly.

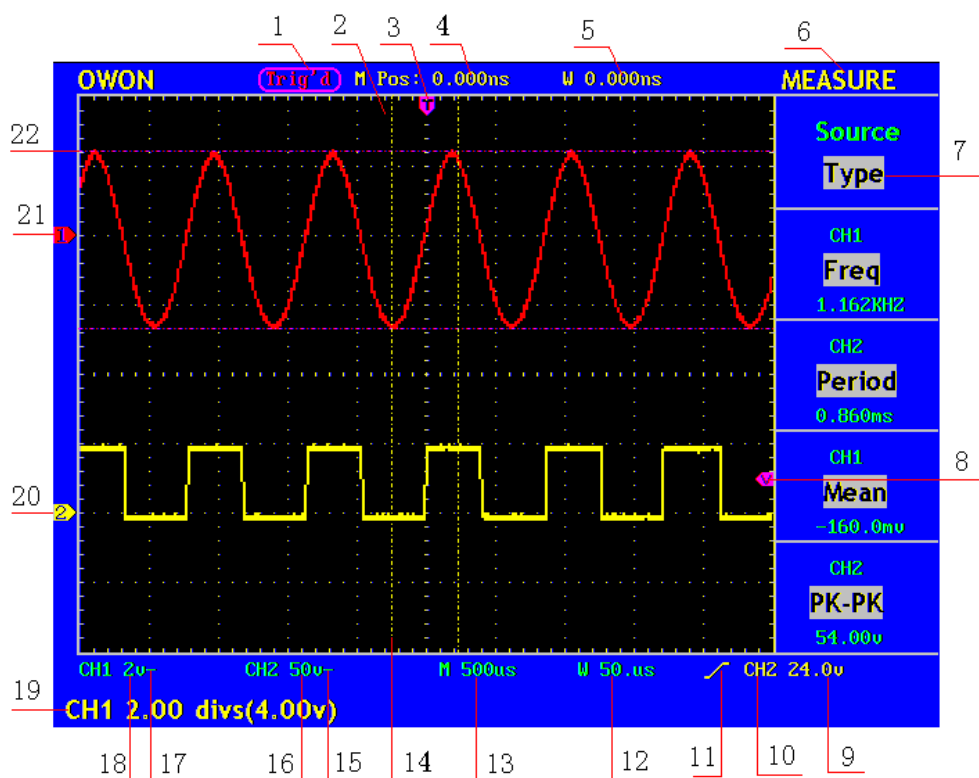


**Fig.1** The Front Panel of a PDS series Oscilloscope

Function Buttons



**Fig.2** Explanatory Drawing for Operations of the PDS series Oscilloscope



**Fig.3** Illustrative Drawing of Display Interfaces

1. The Trigger State indicates the following information:

Auto: The oscilloscope is under the Automatic mode and is collecting the waveform under the non-trigger state.





Trig'd: The oscilloscope has already detected a trigger signal and is collecting the after-triggering information.

Ready: All pre-triggered data have been captured and the oscilloscope has been already ready for accepting a trigger.

Scan: The oscilloscope captures and displays the waveform data continuously in the scan mode.

Stop: The oscilloscope has already stopped the waveform data acquisition.

2. Waveform Viewing Area.
3. The purple pointer indicates the horizontal trigger position, which can be adjusted by the horizontal position control knob.
4. The reading shows the time deviation between the horizontal trigger position and the screen centre line, which equals 0 in the screen center.
5. This reading shows the time deviation between the horizontal trigger position and the window centre line, which is regarded as 0 in the window center.
6. It indicates the current function menu.
7. It indicates the operation options for the current function menu, which changes

- with the function menus.
8. The purple pointer shows the trigger level position.
  9. The reading shows the trigger level value.
  10. The reading shows the trigger source.
  11. It shows the selected trigger type:
    -  Rising edge triggering
    -  Falling edge triggering
    -  Video line synchronous triggering
    -  Video field synchronous triggering
  12. The reading shows the window time base set value.
  13. The reading shows the main time base set value.
  14. The two yellow dotted lines indicate the size of the viewing expanded window.
  15. The icon shows the coupling mode of the CH2 channel.
    - “—” indicates the direct current coupling
    - “ ~ ” indicates the AC coupling
    - “  $\perp$  ” indicates GND coupling.
  16. The reading shows the vertical scale factor (the Voltage Division) of the CH2 channel.
  17. The icon indicates the coupling mode of the CH1 channel:
    - The icon “—” indicates the direct current coupling
    - The icon “~” indicates the AC coupling
    - The icon “  $\perp$  ” indicates GND coupling.
  18. The reading indicates the vertical scale factor (the Voltage Division) of the CH1 channel.
  19. The information shows the zero point positions of CH1 or CH2 channel.
  20. The yellow pointer shows the grounding datum point (zero point position) of the waveform of the CH2 channel. If the pointer is not displayed, it shows that this channel is not opened.
  21. The red pointer indicates the grounding datum point (zero point position) of the waveform of the CH1 channel. If the pointer is not displayed, it shows that the channel is not opened.
  22. The positions of two purple dotted line cursors measurements.

## Check the Package Contents

After you get a new PDS series oscilloscope, it is recommended that you should make a check on the instrument according to the following steps:

### 1. Check whether there is any damage caused by transportation.

If it is found that the packaging carton or the foamed plastic protection cushion has suffered serious damage, do not throw it away first till the complete device and its accessories succeed in the electrical and mechanical property tests.

### 2. Check the Accessories

The supplied accessories have been already described in the **Appendix B** “Accessories” of this Manual. You can check whether there is any loss of accessories with reference to this description. If it is found that there is any accessory lost or damaged, please get in touch with the distributor of LILLIPUT responsible for this service or the LILLIPUT’s local offices.

### 3. Check the Complete Instrument

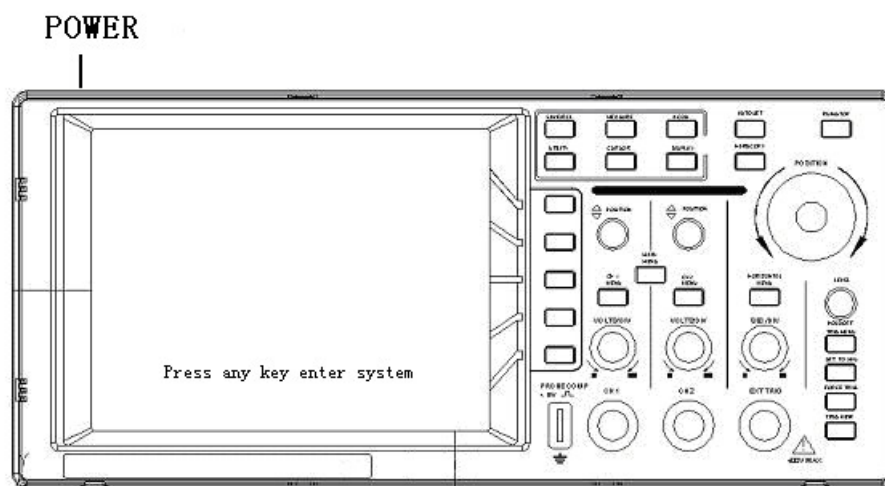
If it is found that there is damage to the appearance of the instrument, or the instrument can not work normally, or fails in the performance test, please get in touch with the LILLIPUT’s distributor responsible for this business or the LILLIPUT’s local offices. If there is damage to the instrument caused by the transportation, please keep the package. With the transportation department or the LILLIPUT’s distributor responsible for this business informed about it, a repairing or replacement of the instrument will be arranged by the LILLIPUT.

## To perform the Function Inspection

Make a fast function check to verify the normal operation of the instrument, according to the following steps:

### 1. Connect the Instrument to the Power and Push down the Power Switch Button.

The instrument carries out all self-check items and shows the prompt “Press any Key Enter the Operating Mode”. Press the “UTILITY” button to get access to the “FUNCTION” menu and push down F2 the menu selection button to call out the function “Recall Factory”. The default attenuation coefficient set value of the probe in the menu is 10X, shown as Fig.4.



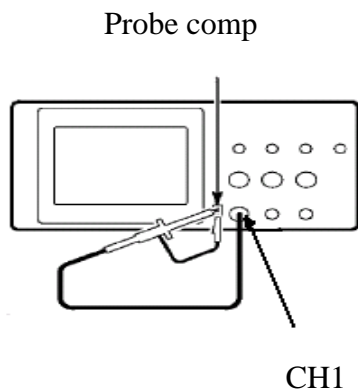
**Fig.4** Power on the Instrument

### 2. Set the Switch in the Oscilloscope Probe as 10X and Connect the Oscilloscope with CH1 Channel.

Align the slot in the probe with the plug in the CH1 connector BNC, and then tighten the probe with rotating it to the right side.

Connect the probe tip and the ground clamp to the connector of the probe compensator, shown as Fig.5.

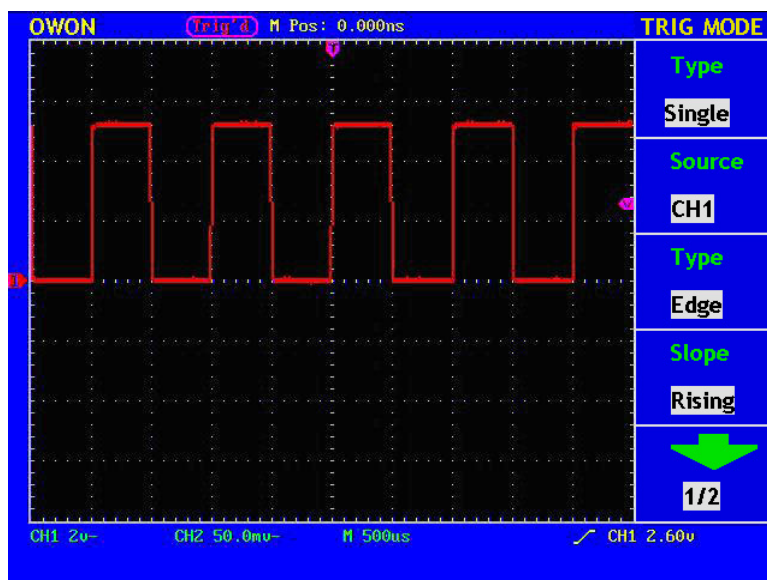




**Fig.5** Connection of the Probe

**3. Press the AUTO SET Button.**

The square wave of 1 KHz frequency and 5V peak-peak value will be displayed in several seconds (see Fig.6).



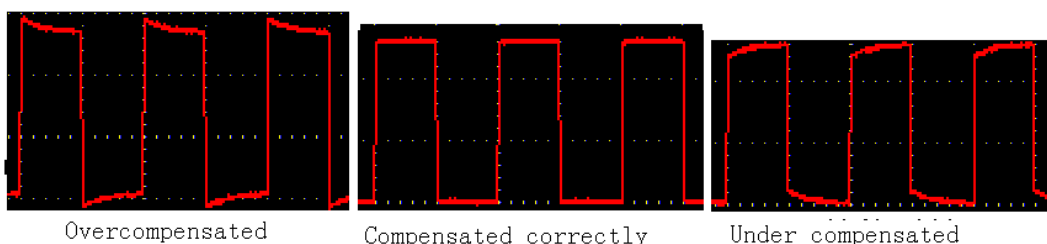
**Fig.6** Auto set

Check CH2 by repeating Step 2 and Step 3.

## To perform the Probe Compensation

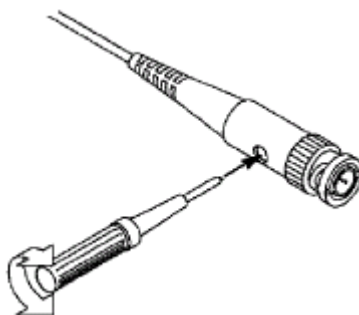
When connect the probe with any input channel for the first time, make this adjustment to match the probe with the input channel. The probe which is not compensated or presents a compensation deviation will result in the measuring error or mistake. For adjusting the probe compensation, please carry out the following steps:

1. Set the attenuation coefficient of the probe in the menu as 10X and that of the switch in the probe as 10X, and connect the oscilloscope probe with the CH1 channel. If a probe hook tip is used, ensure that it keeps in close touch with the probe. Connect the probe tip with the signal connector of the probe compensator and connect the reference wire clamp with the ground wire connector of the probe connector, and then press the button AUTOSSET (see Fig.5).
2. Check the displayed waveforms and regulate the probe till a correct compensation is achieved (see Fig.7 and Fig.8).



**Fig.7** Displayed Waveforms of the Probe Compensation

3. Repeat the steps mentioned if necessary.



**Fig.8** Adjust Probe

## To set the Probe Attenuation Coefficient

The probe has several attenuation coefficients, which will influence the vertical scale factor of the oscilloscope.

If it is required to change (check) the set value of the probe attenuation coefficient, press the function menu button of the channels used, then push down the selection button corresponding to the probe till the correct set value is shown.

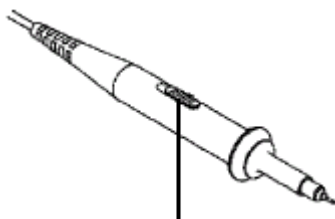
This setting will be valid all the time before it is changed again.



**Note:** The attenuation coefficient of the probe in the menu is preset to 10X when the oscilloscope is delivered from the factory.

Make sure that the set value of the attenuation switch in the probe is the same as the menu selection of the probe in the oscilloscope.

The set values of the probe switch are 1X and 10X (see Fig.9).



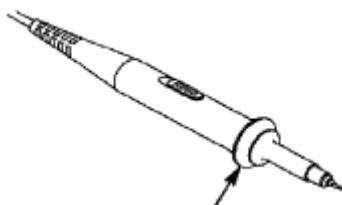
**Fig.9** Attenuation Switch



**Note:** When the attenuation switch is set to 1X, the probe will limit the bandwidth of the oscilloscope in 5MHz. If it is needed to use the whole bandwidth of the oscilloscope, the switch must be set to 10X.

## To use the Probe Safely

The safety guard ring around the probe body protects your finger against the electric shock, shown as Fig.10.



**Fig.10** Finger Guard



**Warning:** In order to avoid suffering from the electric shock, please keep your finger behind the safety guard ring of the probe body during the operation.

In order to protect you from suffering from the electric shock during your using the probe, do not touch the metal part of the probe tip when the probe is connected to the power supply.

Before making any measurements, please connect the probe to the instrument and connect the ground terminal to the earth.

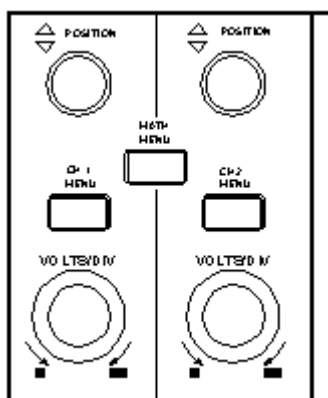
## To perform Self-calibration

The self-calibration application can make the oscilloscope reach the optimum condition rapidly to obtain the most accurate measurement value. You can carry out this application program at any time, but when the range of variation of the ambient temperature is up to or over 5 °C, this program must be executed.

For the performing of the self-calibration, all probes or wires should be disconnected with the input connector first. Then, press the “**UTILITY**” button to call out the **FUNCTION** menu; push down the F3 menu selection button to choose the option “Perform Self-Calibration”; finally, run the program after confirming that everything is ready now.

## Introduction to the Vertical System

Shown as Fig.11, there are a series of buttons and knobs in **VERTICAL CONTROLS**. The following practices will gradually direct you to be familiar with the using of the vertical setting.



**Fig.11** Vertical Control Zone

1. Use the button “VERTICAL POSITION” knob to show the signal in the center of the waveform window. The “VERTICAL POSITION” knob functions the regulating of the vertical display position of the signal. Thus, when the “VERTICAL POSITION” knob is rotated, the pointer of the earth datum point of the channel is directed to move up and down following the wave form.

### Measuring Skill

If the channel is under the DC coupling mode, you can rapidly measure the DC component of the signal through the observation of the difference between the wave form and the signal ground.

If the channel is under the AC mode, the DC component will be removed by filtration. This mode helps you display the AC component of the signal with a higher sensitivity.

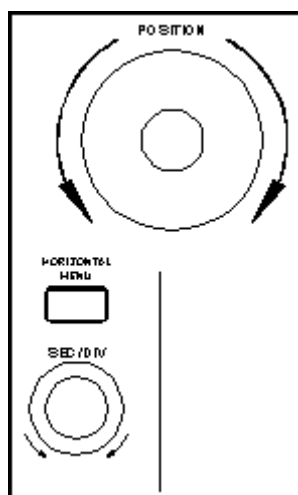
2. Change the Vertical Setting and Observe the Consequent State Information Change.

With the information displayed in the status bar at the bottom of the waveform window, you can determine any changes in the channel vertical scale factor.

- Rotate the vertical “VOLTS/DIV” knob and change the “Vertical Scale Factor (Voltage Division)”, it can be found that the scale factor of the channel corresponding to the status bar has been changed accordingly.
- Press buttons of “CH1 MENU”, “CH2 MENU” and “MATH MENU”, the operation menu, symbols, wave forms and scale factor status information of the corresponding channel will be displayed in the screen.

## Introduction to the Horizontal System

Shown as Fig.12, there are a button and two knobs in the “**HORIZONTAL CONTROLS**”. The following practices will gradually direct you to be familiar with the setting of horizontal time base.

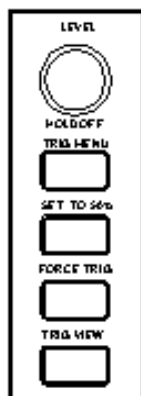


**Fig.12** Horizontal Control Zone

1. Use the horizontal “**SEC/DIV**” knob to change the horizontal time base setting and observe the consequent status information change. Rotate the horizontal “**SEC/DIV**” knob to change the horizontal time base, and it can be found that the “**Horizontal Time Base**” display in the status bar changes accordingly. The horizontal scanning speed steps from 5ns up to 100s according to the stepping mode of  
**1-2.5-5----** PDS5022S/T;  
**1—2—5 ----** PDS6042S, PDS6062S.
2. Use the “**HORIZONTAL POSITION**” knob to adjust the horizontal position of the signal in the waveform window. The “**HORIZONTAL POSITION**” knob is used to control the triggering displacement of the signal or for other special applications. If it is applied to triggering the displacement, it can be observed that the wave form moves horizontally with the knob when you rotate the “**Horizontal Position**” knob.
3. With the “**HORIZONTAL MENU**” button pushed down, you can set and initiate the Window Expansion.

## Introduction to the Trigger System

Shown as Fig.13, there are a knob and four buttons in the “**TRIGGER CONTROLS**”. The following practices will direct you to be familiar with the setting of the trigger system gradually.



**Fig.13** Trigger Control Zone

1. Press the “**TRIG MENU**” button and call out the trigger menu. With the operations of the 5 menu selection buttons, the trigger setting can be changed.
2. Use the “**LEVEL**” knob to change the trigger level setting.  
With the rotation of the “**LEVEL**” knob, it can be found that the trigger indicator in the screen will move up and down with the rotation of the knob. With the movement of the trigger indicator, it can be observed that the trigger level value displayed in the screen changes.
3. Press the button “**SET TO 50%**” to set the trigger level as the vertical mid point values of the amplitude of the trigger signal.
4. Press the “**FORCE TRIG**” button to force a trigger signal, which is mainly applied to the “Normal” and “Single” trigger modes.
5. The “**SET TO ZERO**” button is used to reset the trigger horizontal position.

## Advanced User's Guidebook

Up till now, you have already been familiar with the initial operations of “**VERTICAL CONTROLS**”, “**HORIZONTAL CONTROLS**” and “**TRIGGER CONTROLS**”, and the functions of the function areas, buttons and knobs in the front panel of the PDS series oscilloscope. Based the introduction of the previous Chapter, the user should have an intimate knowledge of the determination of the change of the oscilloscope setting through observing the status bar. If you have not been familiar with the above-mentioned operations and methods yet, we advise you to read the section of “Chapter One Junior Users' Guidebook”.

This chapter will deal with the following topics mainly:

- **To set the Vertical System**
- **To set the Horizontal System**
- **To set the Trigger System**
- **To perform the Sampling Setup**
- **To set the Display System**
- **To Save and Recall a Wave Form**
- **To perform the Auxiliary System Function Setting**
- **To perform the Automatic Measurement**
- **To perform the Cursor Measurement**
- **To use Autoscale function**
- **To use Executive Buttons**

It is recommended that you read this chapter carefully to get acquainted the various measurement functions and other operation methods of the PDS series oscilloscope.



## To set the Vertical System

The **VERTICAL CONTROLS** includes three menu buttons such as **CH1 MENU**, **CH2 MENU** and **MATH MENU**, and four knobs such as **VERTICAL POSITION**, **VOLTS/DIV** (one group for each of the two channels).

### Setting of CH1 and CH2

Every channel has an independent vertical menu and each item is set respectively based on the channel.

With the “**CH1 MENU**” or “**CH2 MENU**” menu button pushed down, the system shows the operation menu of the corresponding channel (see Fig.14). By pressing F1,F2,F3,F4 etc., you can change and select the settings. The following table explains more details of these function and settings.

<b>CH1 SETUP</b>	<b>Function Menu</b>	<b>Setting</b>	<b>Description</b>
<b>Coupling</b> AC	Coupling	AC	Block the DC component from input signal.
<b>Channel</b> ON		DC	Pass both AC and DC components from input signal.
<b>Probe</b> 1 X		Ground	Input signal is interrupted.
<b>Inverted</b> OFF	Channel	OFF ON	Close the measurement channel. Open the measuring channel.
	Probe	1X 10X 100X 1000X	Choose one according to the probe attenuation factor to make the vertical scale reading accurate.
	Inverted	OFF ON	Display original waveform. Display inverted waveform.

**Fig.14** Channel Setting Menu

### 1. Setting Coupling for selected Channel

A square waveform is used as an input in this example.

Press the **CH1 MENU** button to show submenu **CH1 SETUP**.

- Press **F1** next to Coupling and select “AC”, now DC component is blocked from input signal. See Fig.15.
- Press **F1** again to set “DC” mode, both AC and DC components get passed. See Fig.16.

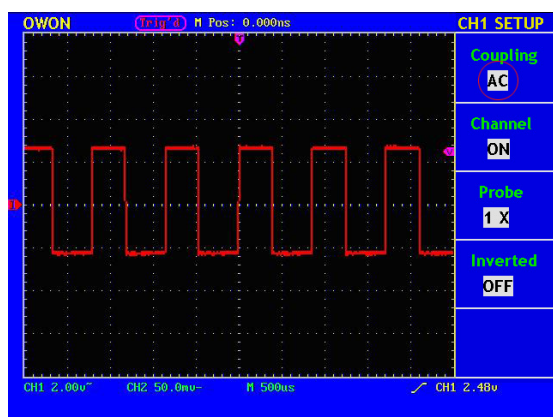


Fig.15 AC Coupling

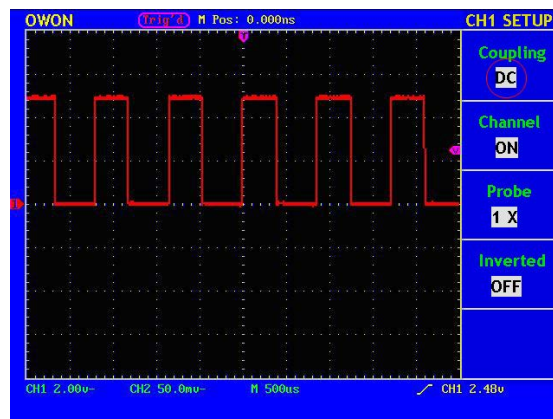


Fig.16 DC Coupling

## 2. Setting the Channel “ON/OFF”

Taking the Channel 1 for example, the operation steps are shown as below:

- (1). Press the **CH1 MENU** button and call out the **CH1 SETUP** menu.
- (2). Press the **F2** menu selection button and select the Channel as **OFF**, with Channel 1 switched off.
- (3). Press **F2** menu selection button again, select the channel as **ON**, with Channel 1 is switched on.

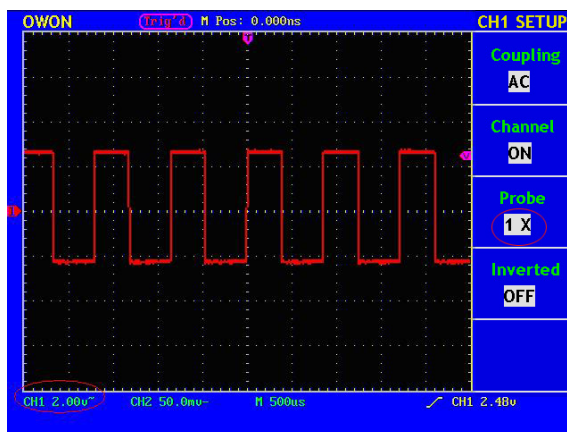
## 3. Regulate the Attenuation Ratio of the Probe

In order to match the attenuation coefficient of the probe, it is required to adjust the attenuation ratio coefficient of the probe through the operating menu of the Channel accordingly. If the attenuation coefficient of the probe is 1:1, that of the oscilloscope input channel should also be set to 1X to avoid any errors presented in the displayed scale factor information and the measured data.

Take the Channel 1 as an example, the attenuation coefficient of the probe is 1:1, the operation steps is shown as follows:

- (1). Press the **CH1 MENU** button, access CH1 SETUP menu.
- (2). Press the **F3** menu selection button and select 1X for the probe.

The Fig.17 illustrates the setting and the vertical scale factor when the probe of the attenuation coefficient of 1:1 is used.



**Fig.17** Regulation of the Attenuation Ratio of the Probe

A List of the Attenuation Coefficients of Probes and the Corresponding Menu Settings.

Attenuation Coefficient of the Probe	Corresponding Menu Setting
1:1	1X
10:1	10X
100:1	100X
1000:1	1000X

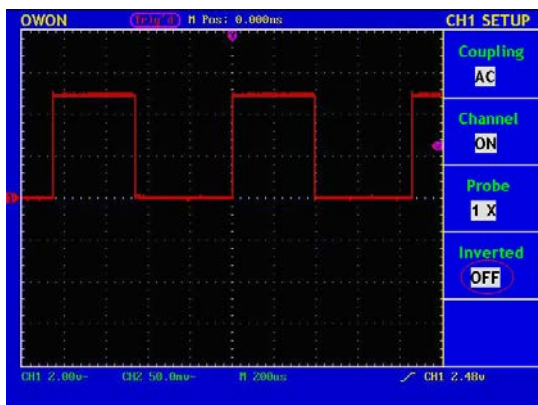
**4. Setting of Wave Form Inverted**

Wave form inverted: the displayed signal is turned 180 degrees against the phase of the earth potential.

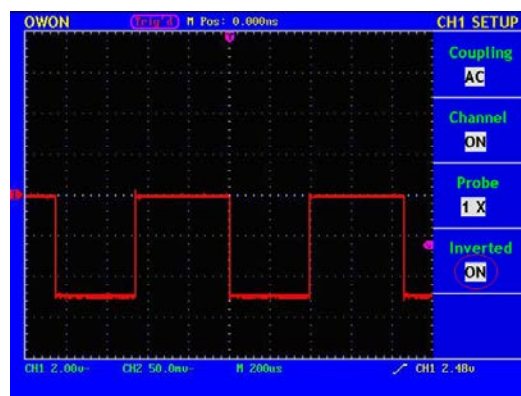
Taking the Channel 1 for example, the operation steps are shown as follows:

- (1). Press the **CH1 MENU** button and get access to the **CH1 SETUP** menu.
- (2). Press the **F4** menu selection button and select **ON** in the **Inverted**. The wave form inverted function is initiated.
- (3). Press the **F4** menu selection button again and select OFF for **Inverted** item. The function of wave form inverted is closed off.

For the screen display, see Fig.18 and Fig.19.



**Fig.18** Original Wave Form



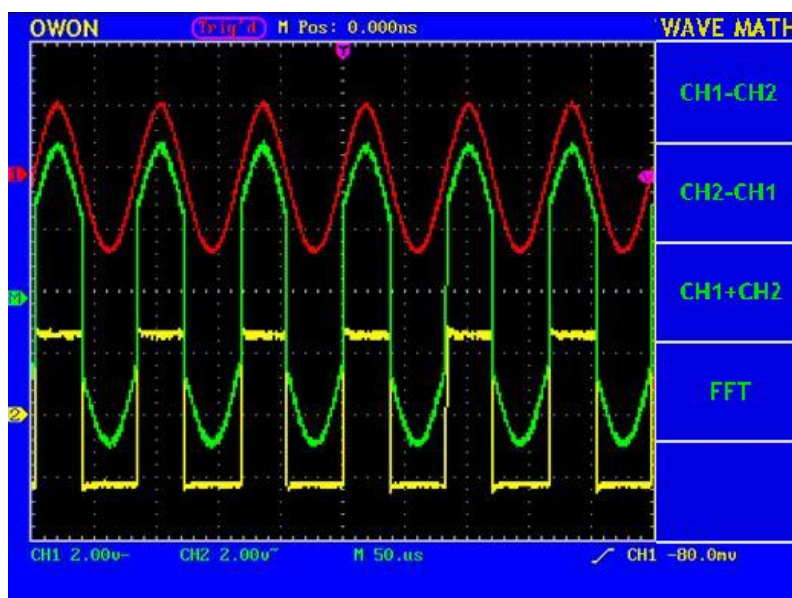
**Fig.19** Inverted Wave Form

## Perform Mathematical Manipulation Function

The **Mathematical Manipulation** function is used to show the results of the additive and subtraction operations between Channel 1 and Channel 2, and the FFT operation of CH1 or CH2.

Taking the additive operation between Channel 1 and Channels 2 for example, the operation steps are as follows:

1. Press the **MATH MENU** button and call out the **WAVE MATH** menu.
2. Press the **F3** menu selection button and choose **CH1+CH2**. The green calculated wave form M is displayed in the screen; press the **F3** menu selection button again, the wave form M is closed off (see Fig.20).



**Fig.20** Wave Form resulted from CH1 +CH2 Mathematical Manipulation

The corresponding FCL (Functional Capabilities List) of the **Wave Form Calculation**

Setting	Description
CH1-CH2	Subtract the Channel 2 wave form from the Channel 1 wave form.
CH2-CH1	Subtract the Channel 1 wave form from the Channel 2 wave form.
CH1+CH2	Add the Channel 1 wave form to the Channel 2.
FFT	Waveform of Corresponding FFT operation

### Using FFT function

An FFT breaks down signals into component frequencies, which the oscilloscope uses to display a graph of the frequency domain of a signal, as opposed to the oscilloscope's

standard time domain graph. You can match these frequencies with known system frequencies, such as system clocks, oscillators, or power supplies.

FFT in this oscilloscope can transform 2048 points of the time-domain signal into its frequency components and the final frequency contains 1024 points ranging from 0Hz to Nyquist frequency.

The following table describes the FFT menu:

Function Menu	Setting	Instruction
FFT	ON	Turn on FFT function
	OFF	Turn off FFT function
Source	CH1	Select CH1 as FFT source
	CH2	Select CH2 as FFT source
Window	Rectangle	Select window for FFT.
	Blackman	
	Hanning	
	Hamming	
Format	dB	Select dB for Format
	Vrms	Select Vrms for Format
Zoom	*1	Set multiple *1
	*2	Set multiple *2
	*5	Set multiple *5
	*10	Set multiple *10




Taking the FFT operation for example, the operation steps are as follows:

1. Press **F1** once to turn on FFT, Press again to turn it off. Be aware that only to use FFT when Horizontal Menu is set for main Timebase Not on Window setting mode. Again, the green waveform is displayed as a result of FFT.
2. Press **F2** to switch the FFT between CH1 and CH2.
3. Press **F3** to choose WINDOW for FFT, there are four options here, including Rectangle、Hamming、Hanning and Blackman. We will give details of these options later.
4. Press **F4** to switch between dB and Vrms.

5. Press **F5** to zoom in/out, options including multiplied \*1, \*2, \*5, \*10.
6. Adjust the “**Horizontal**” knob in horizontal control zone to move the waveform and the shown frequency of M Pos is the exact frequency of the cursor point in the middle of spectrum.
7. Press **F1** to turn off FFT and then press **math menu** to go back to WAVE MATH menu.

### Selecting an FFT Window

■ The FFT feature provides four windows. Each one is a trade-off between frequency resolution and magnitude accuracy. What you want to measure and your source signal characteristics help determine which window to use. Use the following guidelines to select the best window.

Type	Description	Window
Rectangle	<p>This is the best type of window for resolving frequencies that are very close to the same value but worst for accurately measuring the amplitude of those frequencies. It is the best type for measuring the frequency spectrum of nonrepetitive signals and measuring frequency components near DC.</p> <p>Use rectangle for measuring transients or bursts where the signal level before and after the event are nearly equal. Also, use this window for equal-amplitude sine waves with frequencies that are very close and for broadband random noise with a relatively slow varying spectrum.</p>	
Hamming	<p>This is a very good window for resolving frequencies that are very close to the same value with somewhat improved amplitude accuracy over the rectangle window. It has a slightly better frequency resolution than the Hanning.</p> <p>Use Hamming for measuring sine, periodic, and narrow band random noise. This window works on transients or bursts where the signal levels before and after the event are significantly different.</p>	
Hanning	<p>This is a very good window for measuring amplitude accuracy but less so for resolving frequencies.</p> <p>Use Hanning for measuring sine, periodic and narrow band random noise. This window works on transients or bursts where the signal levels before and after the event are significantly different.</p>	


<p>Blackman</p>	<p>This is the best window for measuring the amplitude of frequencies but worst at resolving frequencies. Use Blackman-Harris for measuring predominantly single frequency waveforms to look for higher order harmonics.</p>	
-----------------	--	---

Fig.21, 22, 23, 24 show four kinds of window function referring to sine wave of 1 KHz.

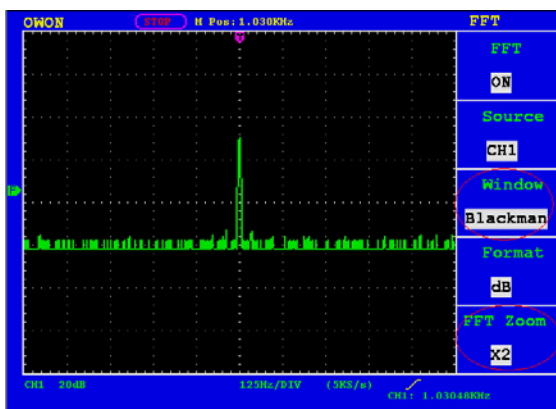


Fig.21 Blackman window

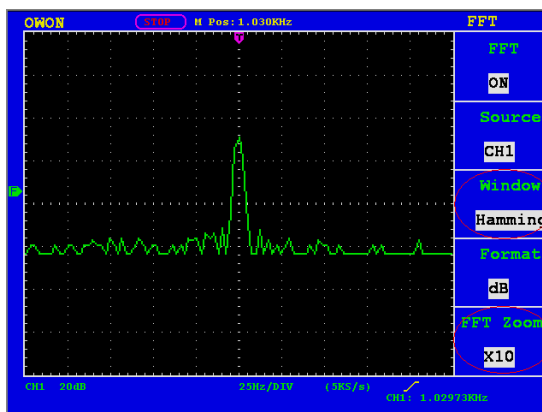


Fig.22 Hamming window

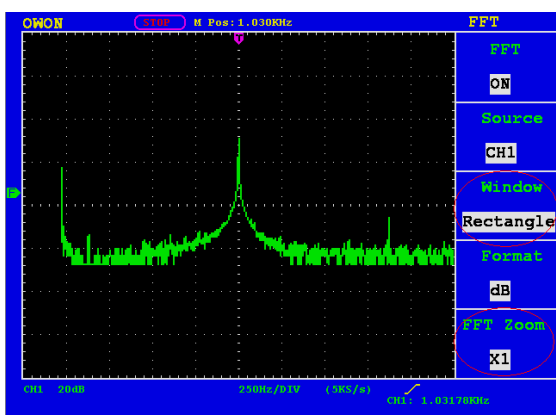


Fig.23 Rectangle window

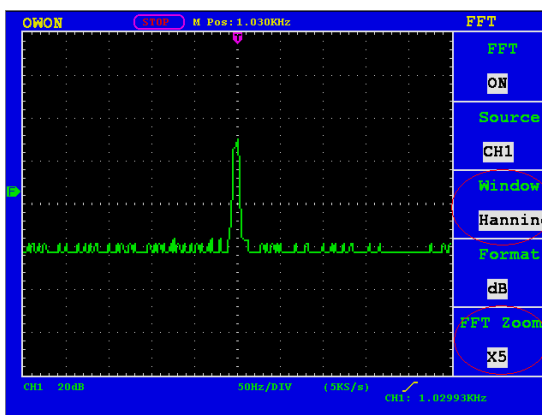


Fig.24 Hanning window

### Quick Tips

- If desired, use the zoom feature to magnify the FFT waveform.
- Use the default dBV RMS scale to see a detailed view of multiple frequencies, even if they have very different amplitudes. Use the linear RMS scale to see an overall view of how all frequencies compare to each other.
- Signals that have a DC component or offset can cause incorrect FFT waveform component magnitude values. To minimize the DC component, choose AC Coupling on the source signal.
- To reduce random noise and aliased components in repetitive or single-shot events, set

the oscilloscope acquisition mode to average.

### **Term interpretation**

**Nyquist frequency:** The highest frequency that any Real Time Digital Oscilloscope can measure is exactly half of the sampling rate under the condition of no mistakes, which is called Nyquist frequency. If under-sampling occurs when the frequency sampled is higher than Nyquist frequency, “False Wave” phenomenon will appear. So pay more attention to the relation between the frequency being sampled and measured.

### **NOTE:**

While FFT mode is turned on, **DO NOT USE THESE SETTINGS:**

- 1) Horizontal window setting.
- 2) Change source channel in CH1/CH2 Setup menu
- 3) Turn on XY Format
- 4) Trigger control “SET 50%”
- 5) Auto-scale function

## **Application of VERTICAL POSITION and VOLTS/DIV Knobs**

1. The **.VERTIVAL POSITION** knob is used to adjust the vertical positions of the wave forms of all Channels (including those resulted from the mathematical operation).  
The analytic resolution of this control knob changes with the vertical division.
2. The **VOLTS/DIV** knob is used to regulate the vertical resolution of the wave forms of all channels (including those obtained from the mathematical manipulation), which can determine the sensitivity of the vertical division with the sequence of 1—2—5. The vertical sensitivity goes up when the knob is rotated clockwise and goes down when the knob is rotated anticlockwise.
3. When the vertical position of the channel wave form is adjusted, the screen shows the information concerning the vertical position at the lower left corner (see Fig.25).



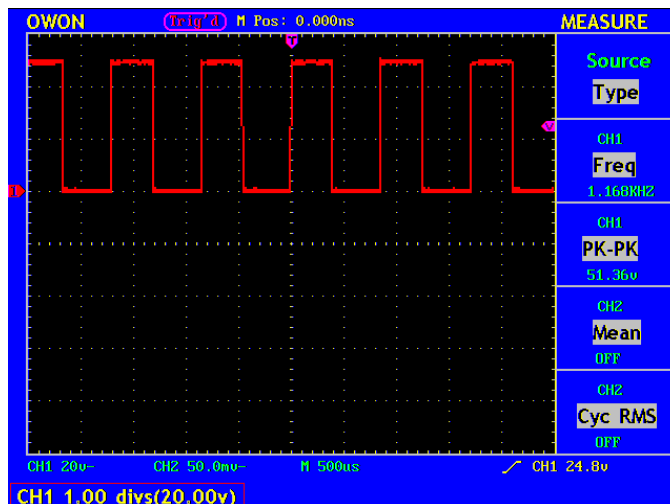


Fig.25 Information about Vertical Position

### To set the Horizontal system

The **HORIZONTAL CONTROLS** includes the **HORIZONTAL MENU** button and such knobs as **HORIZONTAL POSITION** and **SEC/DIV**.

1. **HORIZONTAL POSITION** knob: this knob is used to adjust the horizontal positions of all channels (include those obtained from the mathematical manipulation), the analytic resolution of which changes with the time base.
2. **SEC/DIV** knob: it is used to set the horizontal scale factor for setting the main time base or the window.
3. **HORIZONTAL MENU** button: Press this button to active **TIME MODE** shown as below with description of each function. (see Fig.26).



Function Menu	Setting	Description
Main Time Base		The setting of the horizontal main time base is used to display the wave form.
Set Window		A window area is defined by two cursors.
Zone Window		The defined window area for display is expanded to the full screen.

Fig.26 Time Mode

## Main Time Base

Press the **F1** menu selection button and choose the **Main Time Base**. In this case, the **HORIZONTAL POSITION** and **SEC/DIV** knobs are used to adjust the main window. The display in the screen is shown as Fig.27.

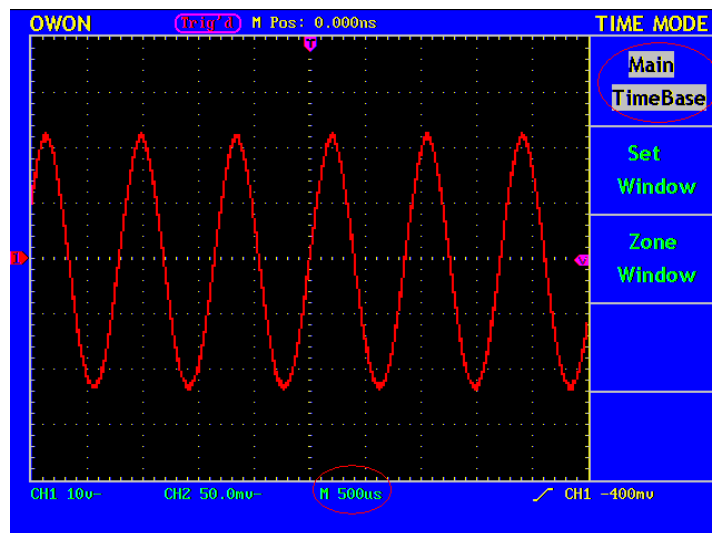


Fig.27 Main Time Base

## Window Setting

Press the **F2** menu selection button and choose **Set Window**. The screen will show a window area defined by two cursors. In this case, the **HORIZONTAL POSITION** and **SEC/DIV** knobs can be used to adjust the horizontal position and size of this window area (see Fig.28).

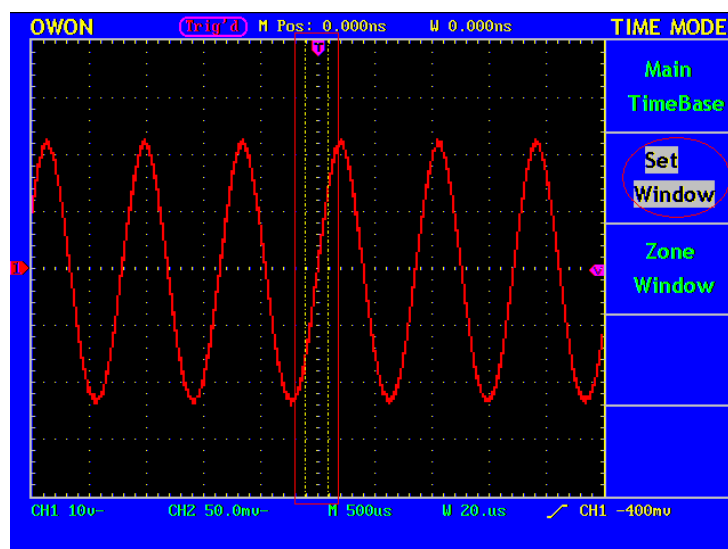
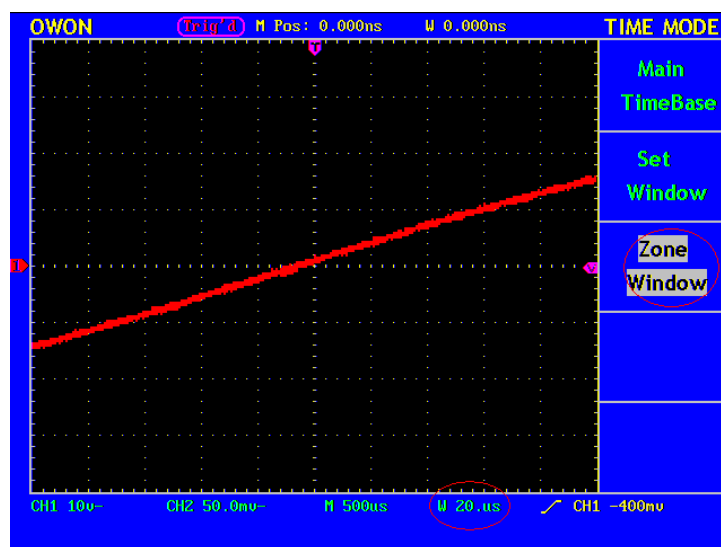


Fig.28 Set Window

## Zoom in

Press the **F3** menu selection button and choose **Zone Window**. As a result, the window area defined by two cursors will be expanded to the full screen size (see Fig.29).



**Fig.29** Zone Window

## To set the Trigger System

When the oscilloscope begins to collect the data and display the wave form depends on a trigger. Once it is set correctly, the trigger can transfer the unstable display into a meaningful wave form.

When beginning to collect data, the oscilloscope will collect adequate data to draw the wave form at the left side of the trigger point at first. It will continuously perform the data acquisition while waiting for the trigger condition. After a trigger is detected, the oscilloscope will continuously collect data enough to draw the wave form at the right side of the trigger point.

One knob and four function menu buttons are included in the trigger control zone.

**TRIG LEVEL:** Trigger the level control knob and set the signal voltage corresponding to the trigger point.

**SET TO 50%:** Set the trigger level as the vertical mid point value of the amplitude of the trigger signal.

**FORCE TRIG:** It is a force trigger button for the generation of a trigger signal, which is mainly used in the "Normal" and "Single" triggering modes.

**SET TO ZERO:** Trigger the resetting of the horizontal position.

**TRIG MENU:** It is a trigger menu button. When it is pressed, an operation menu will be presented in the screen.

## Trigger Control

**Trigger Control:** There are two trigger modes----Edge Trigger and Video Trigger. Each trigger mode has its function menu for users to set them up. Press **Trigger Menu** to active your trigger setting. Press **F1** next to the display to switch trigger from one type to another.

**Edge Trigger:** It happens when the trigger input passes through a given level along the set direction.

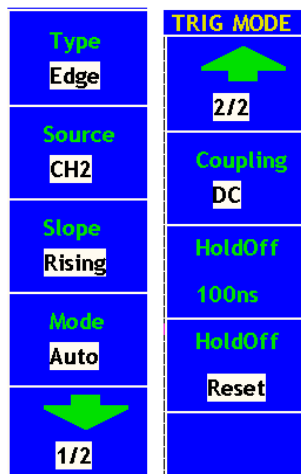
**Video Trigger:** Carry out the field or line video trigger of the standard video signal.

The Edge and Video Trigger menus are described respectively as below:

### Edge Trigger

Under the Edge Trigger mode, a trigger happens in the trigger threshold value of the input signal edge. When the **Edge Trigger** is selected, a trigger will occur in the rising or falling edge of the input signal.



The **Edge Trigger Menu** is shown as Fig.30.



**Fig.30** Edge Trigger Menu

The **Edge Trigger Menu** is described as below:

Function Menu	Setting	Description
Source	CH1	Channel 1 as the trigger source.
	CH2	Channel 2 as the trigger source.
	EXT	Use external source.
	EXT/5	1/5 of the External Trigger Source for increasing range of level.
Slope	Rising	Trigger on the rising edge.
	Falling	Trigger on the falling edge.
Mode	Auto	Acquire data and display waveform with or without a trigger.
	Normal	Acquire data and display waveform when trigger.

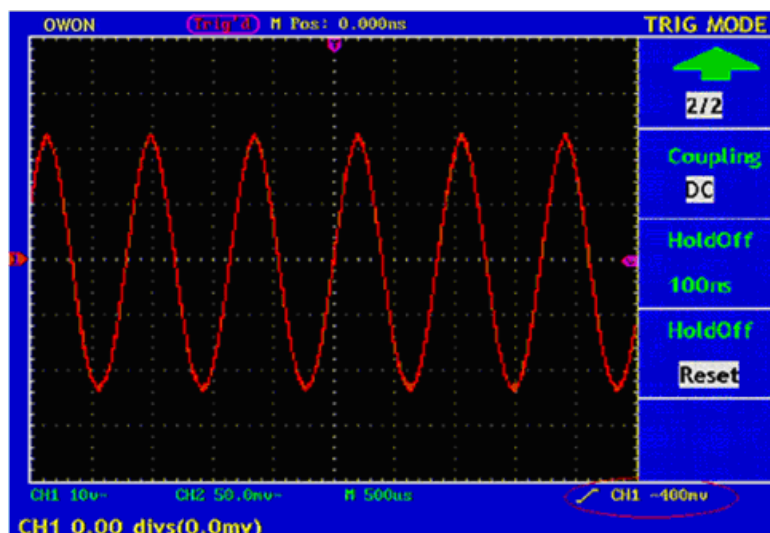
	Single	Acquire data and display waveform when detecting a trigger and stop sampling.
Coupling	AC	Block the direct current component.
	DC	Unblock all components.
	HF Rjc	Block the high-frequency signal and only unblock the low-frequency component.
	LF Rjc	Block the low-frequency signal and only unblock the high -frequency component.
		To next menu
		Back to previous menu
HoldOff	100ns~ 10s	Set interval by using TRIG LEVEL control, value range from 100ns to 10s.
Holdoff Reset		Reset hold time to default value (100ns).

**Holdoff:** A time interval before the oscilloscope responds to next trigger signal. During this Holdoff period, the trigger system becomes “blind” to trigger signals. This function helps to view complex signals such as an AM waveform. Press Function next to Holdoff to activate and use “TRIG LEVEL” knob to set time for Holdoff.

#### Set up a Rising/Falling for edge trigger

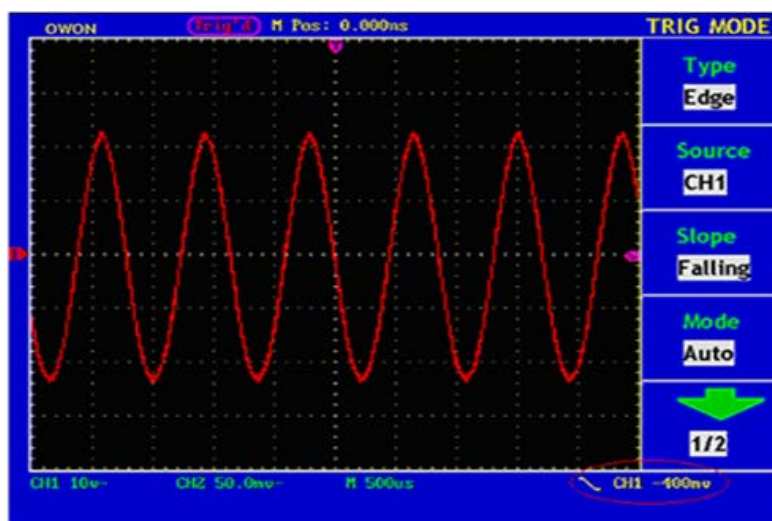
Applying Sine Waveform to CH1:

1. Press the TRIG MENU button c the trigger menu.
2. Press **F1** next to Type and select Edge.
3. Press the **F2** next to Channel and choose CH1 for Source.
4. Press the **F3** next to Slope to choose Rising.
5. Press the **F4** next to Mode to choose Auto.
6. Press **F5** to go down next.
7. Press **F2** next to Coupling and choose DC. You now have waveform displayed as Fig.31.
8. Press **F3** next to Holdoff and use “TRIG LEVEL” knob to set time.



**Fig.31** Waveform when Triggered on Rising Edge

9. Press **F1** Arrow sign to return to previous menu.
10. Press **F3** next to Slope to choose Falling option, see Fig.32.



**Fig.32** Waveform when Triggered on Falling Edge

## Video Trigger



After choosing “**Video Trigger**”, a trigger is possible in field or line of NTSC, PAL or SECAM standard video signal.

The operation menu of **Video Trigger** is shown as Fig.33.



Fig.33 Video Trigger Menu

The description of the **Video Trigger** menu is shown the following table:

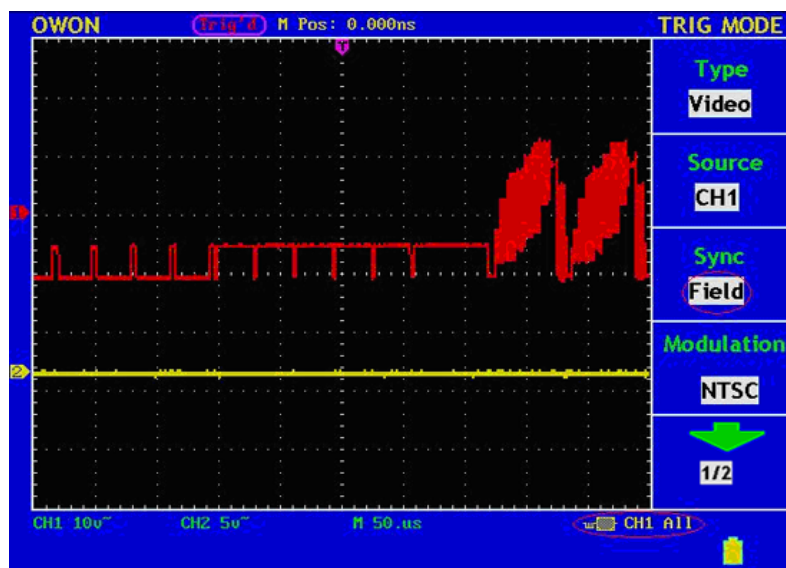
Function Menu	Setting	Description
Source	CH1 CH2 EXT EXT/5	Channel 1 as the trigger source. Channel 2 as the trigger source. Use external source. 1/5 of the External Trigger Source for increasing range of level.
Sync	Line Field Odd field Even field Designed Line	Trigger the time base on the line of input video signal. Trigger the time base on the field of input video signal.. Trigger the odd fields of input video signal. Trigger the even fields of input video signal. Trigger the time base on chosen line of input video signal.
Modulation	NTSC PAL/SECAM	Format of video signal.
		Move to next submenu.
		Back to previous menu.
HoldOff	100ns~10s	Set interval by using <b>TRIG LEVEL</b> control, value range from 100ns to 10s.
HoldOff Reset		Reset hold time to default value (100ns).

### Set up a Video Trigger

#### Apply NTSC video to CH1.

1. Press the **TRIG MENU** to activate **TRIG MODE**.
2. Press **F1** next to Type to select Video for the trigger type.

3. Press the **F2** to choose CH1 for trigger source.
4. Press **F3** next to Sync and select **Field**. The screen display is shown as Fig.34.



**Fig.34** Video Trigger (Sync mode: Field )

### Term interpretation

**Trigger modes:** There are three kinds of trigger modes available for this oscilloscope, which is, auto, normal and single.

**Automatic trigger mode:** The oscilloscope can acquire the waveform without any triggering condition detected in this mode, in which it will be triggered compulsively when waiting for a specified period of time without any triggering condition ignited. When an invalid trigger is enforced, the oscilloscope can not keep the waveform in phase.

**Normal trigger mode:** In this mode, the oscilloscope cannot acquire the waveform till it is triggered. When there is not any trigger, the oscilloscope will display the origin waveform without new waveforms captured.

**Single shot mode:** In this mode, the oscilloscope will detect a trigger and capture a waveform at each time when the customer presses the RUN/STOP key.

**Sensitivity:** Trigger circuit including sluggish in order to exclude the influences from signal noise and get the stable trigger. The sluggish is adjustable among 0.2div~1.0div. It means when set on 1.0 div trigger circuit don't have any response to any signal of PK-PK range  $\leq 1.0$ div which to exclude the influences from signal noise.

**Holdoff:** A time interval before the oscilloscope responses to next trigger signal. During this Holdoff period, the trigger system becomes "blind" to trigger signals. This function helps to view complex signals such as an AM waveform. Press Holdoff button to activate "TRIG LEVEL" knob, then turn it to adjust Holdoff time.

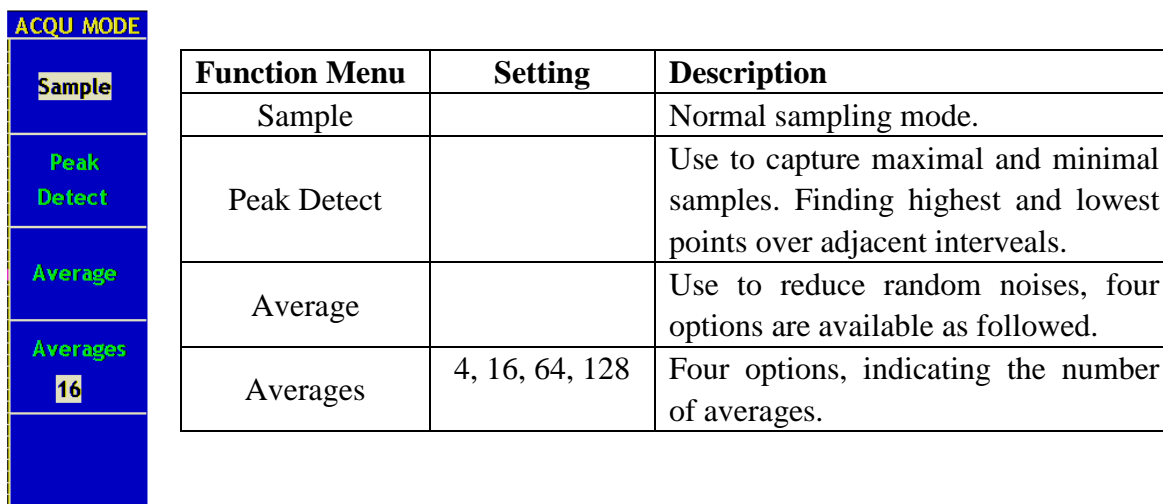


## To operate the Function Menu

The function menu control zone includes 6 function menu buttons and 3 immediate-execution buttons: **SAVE/RCL**, **MEASURE**, **ACQUIRE**, **UTILITY**, **CURSOR**, **DISPLAY**, **AUTOSCALE**, **AUTOSET** and **RUN/STOP**.

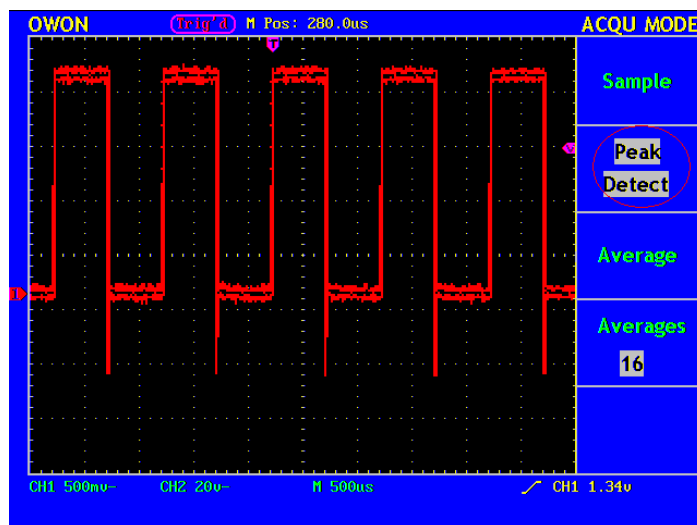
## To perform Sampling Setup

Press the **ACQUIRE** button and the menu is displayed in the screen, shown as Fig.43.



**Fig.35** ACQU MODE Menu

Here is an example for using Peak Detect function, the input is a standard test square waveform. You can see the “burrs” on the falling edge of signal is detected with noise when it is turned on.



**Fig.36** Peak Detect mode

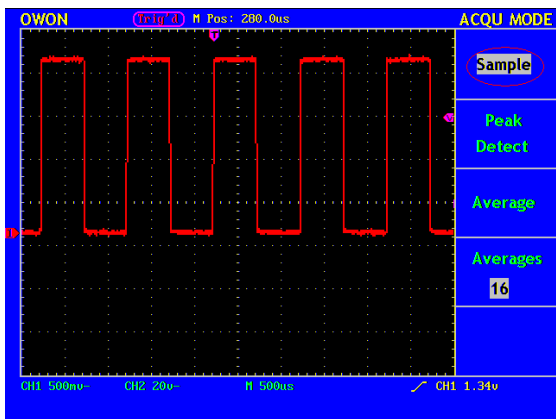


Fig.37 Normal ACQU Mode

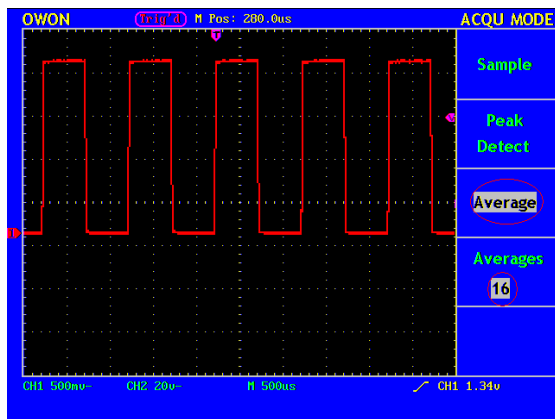


Fig.38 Average on with reduced noise on waveform

## To set the Display System

Press **DISPLAY** once to activate DISP SETUP menu as shown as Fig.47.

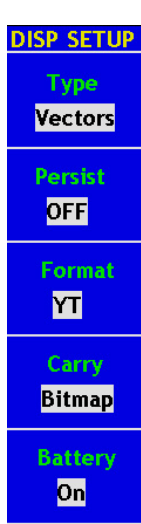


Fig.39 Display Menu

Function Menu	Setting	Description
Type	Vectors	The adjacent sampling points are joined by vector form.
	Dots	Only displaying sampling points captured..
Persist	OFF	Options for setting the persistence time for each sampling point.
	1sec	
	2sec	
	5sec	
	Infinite	
Format	YT	Show waveform as voltage against time.
	XY	Show waveform as CH1(X) against CH2(Y)
Carry	Bitmap	Transmit data in bitmap.
	Vectors	Transmit data in vector.
Battery	On	Show battery level
	Off	Turn off battery level

## Display Type

Press **F1** next to **Type** to change from **Vectors** to **Dots**. Fig.40 and Fig.41 show waveform in different type.

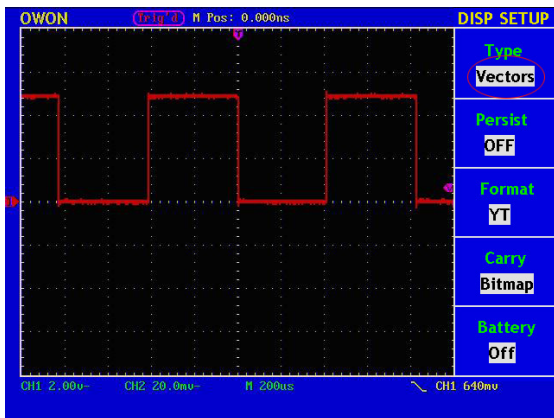


Fig.40 Display in the Vector Form

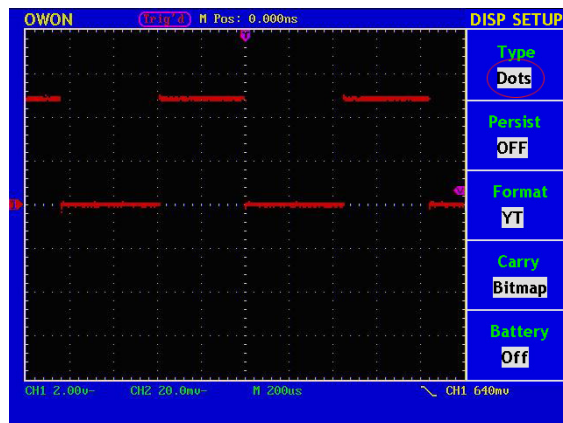


Fig.41 Display in Dots form

### Persist

When the **Persist** function is used, the persistence display effect of the picture tube oscilloscope can be simulated: the reserved original data is displayed in fade color and the new data is in bright color. With the **F2** menu selection button, different persistence time can be chosen: **1sec**, **2sec**, **5sec**, **Infinite** and **Closed**. When the “**Infinite**” option is set for **Persist** time, the measuring points will be stored till the controlling value is changed (see Fig.42).

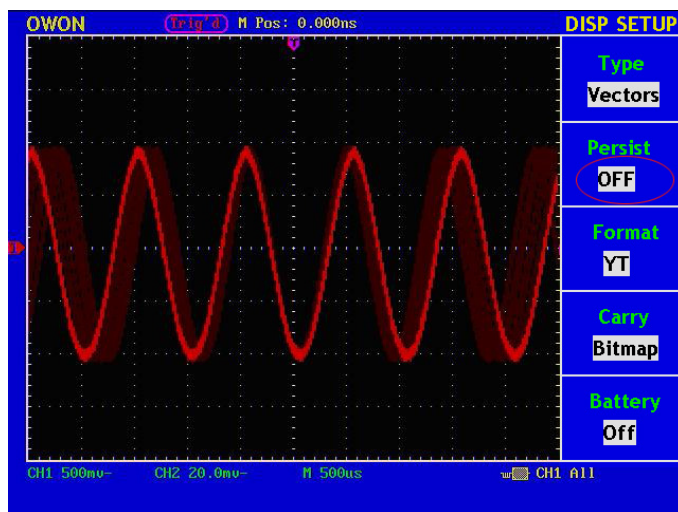


Fig.42 Infinite Persistence Display

### XY Format

This format is only applicable to Channel 1 and Channel 2. After the XY display format is selected, Channel 1 is displayed in the horizontal axis and Channel 2 in the vertical axis; the oscilloscope is set in the untriggered sample mode: the data are displayed as bright spots and the sampling rate is 1MS/s and can not be changed.

**The operations of all control knobs are as follows:**

- The **Vertical VOLTS/DIV** and the **Vertical POSITION** knobs of Channel 1 are

used to set the horizontal scale and position.

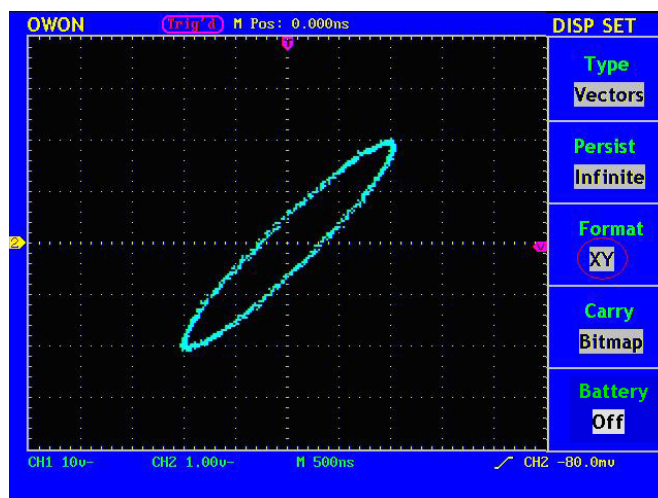
- The **Vertical VOLTS/DIV** and the **Vertical POSITION** knobs of Channel 2 are used to set the vertical scale and position continuously.

**Notes: The following functions would be disabled when XY Format is set.**

- Reference or Any calculated I wave form
- Cursor Function
- All time base controls
- All Trigger controls

### Use XY Format

1. Apply input signals to both CH1 and CH2
2. Press the **DISPLAY** to activate **DISP Set** menu.
3. Press **F1** to set Vectors as type, **F2** to set Infinite for persist and **F3** to set XY as Format as shown as Fig.43



**Fig.43** Display in XY Format

## To Save and Recall a Waveform

Our PDS series Digital Oscilloscope is capable to save up to four wave forms. Stores waveform can be recalled for review later. To active this function, Press the **SAVE/RCL** to bring up **WAVE SAVE** menu. Details of setting and functions are shown in Fig.44.

Function Menu	Setting	Description
Source CH1	CH1 CH2 MATH	Source of wave form to be saved. Available sources:CH1,CH2,MATH
WAVE A	A , B C , D	Location where selected waveform to be saved or recalled.
Save		Action to save selected waveform to selected location.
CH(X) X=A,B,C,D	OFF ON	Turn Display on/off for selected and stored waveform.

Fig.44

### Save a waveform

A sine wave form input CH1. Follow these steps to save waveform from CH1.

- Under WAVE SAVE MENU, press F1 next to Source to select CH1.
- Press F2 next to WAVE to assign Location A for this waveform.
- Press F3 next to Save to store the waveform captured from CH1.

### Recall a stored waveform

Once the waveform is stored you can recall and display it on the screen. The waveform would remain there until the next one is stored at the same location, hence, the previous stored waveform would be overwritten by the new one.

To recall a stored waveform, activate WAVE SAVE menu

- Press F2 next to Wave to select from one of four locations, the CH(X) would show the location you've chosen.
- Press F4 next to CH(X) to change to ON. Now you will see a stored waveform displayed on the screen with whatever waveforms are already on there.
- Example to save/recall a waveform from location A. Fig.45.

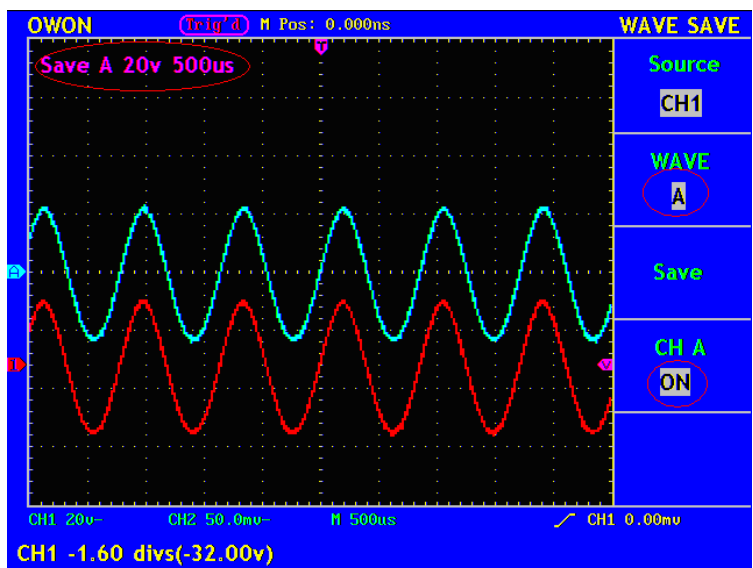


Fig.45 Wave SAVE/RCL

### To perform the Auxiliary System Function Setting

Press the **UNTILITY** button and the menu is displayed in the screen as Fig.46.

FUNCTION	Function Menu	Setting	Description
System Status	System Status		Display the system function menu.
Recall Factory	Recall Factory		Reset system settings to factory default .
Do Self Cal	Do Self Cal		Carry out internal Calibration according to pre-set procedures.
Language English	Language	Chinese English German Chinese ...	Support multi-languages, choose you preferred system language.

Fig.46 Function Menu

### Carry out a Self-Calibration

We have a built-in Self-Calibration procedure, by performing a Self-Calibration would help to maintain the accuracy of your oscilloscope under ambient temperature. It is recommended to carry a self-Calibration if the change of the ambient temperature is up to or exceeds 5°C.

**Notes: Disconnect all inputs before carrying out a self-calibration. Fail to do so may cause damage to your oscilloscope.**

Here are the procedures for carrying a self-calibration.

- Disconnect all inputs, including probes and wires etc.
- Press **UTILITY** to activate Function menu.
- Press **F3** next to Do Self-Cal.

Now there is a yellow window popping up to ask for a confirmation. Press F3 again, the Oscilloscope starts the self-calibration and yellow window remains the calibration is done. **Please be ware that no contacts to any inputs channels till the calibration is done.**

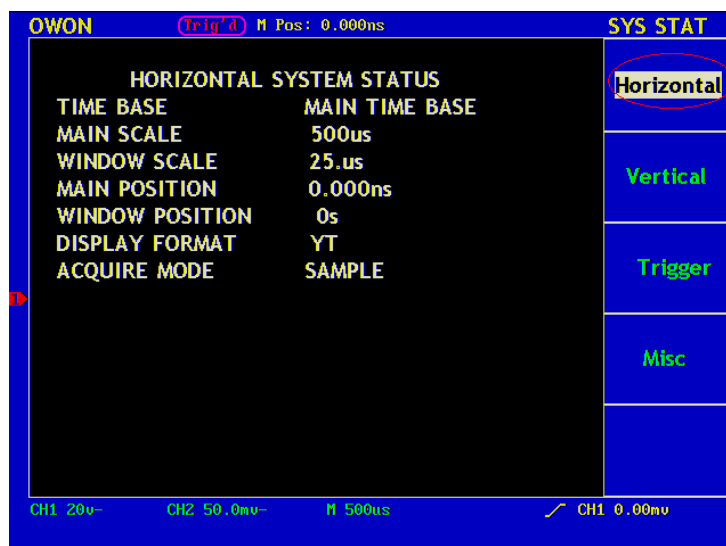
## SYS STAT (System State)

Press the **F1** menu selection button and choose “**SYS STAT**” item. The menu pops up in the screen as Fig.47.

SYS STAT		Function Menu	Setting	Description
Horizontal		Horizontal		Show the horizontal parameter of the channel.
Vertical		Vertical		Show the vertical parameter of the channel.
Trigger		Trigger		Show the parameters of the trigger system.
Misc		Misc		Show the serial number and edition number.

**Fig.47** SYS STAT Menu

After entering into the SYS STAT menu, choose the corresponding function, with the corresponding parameters shown in the screen. If press the **F1** menu selection button and choose the function item “**Horizontal**”, the Horizontal System State will be displayed in the screen. Press any other function button and exit from the SYS STAT menu (see Fig.48).



**Fig.48** Horizontal System State

## To perform the Automatic Measurement

This is where users would come across every time they use our scopes. It is take the measurements by using oscilloscope. Our oscilloscope does this automatic every time user press Measure button. It is capable to work out 20 different types of measurements, and there are 4 measurements can be displayed on the screen at one time.

The 20 types automatic measurements include frequency, cycle, average value, peak-to-peak value , root mean square value, Vmax, Vmin, Vtop, Vbase, Vamp, Overshoot, Preshoot, RiseTime, Fall Time, +Width, -Width, +Duty, -Duty, DelayA->B  $\rightarrow$  and DelayA->B  $\leftarrow$ .

To use Measure, simply Press Measure button would activate MEASURE menu. Press F1 next to Source/Type to allow you to switch between Source and Type.

Source is the signal from the channel which user to carry out a measurement, and Type is one of the 20 measurements user wants Oscilloscope to work out. Under the Type as you can see in Fig.57 is what the actual measurement reading is. The reading would show sign of “?” if there isn’t a measurement can be worked out from the source signal. As in Fig.57, both Channel1 and Channel2 are chosen as source, measurements are taken for Frequency, Pk-Pk value, Mean and RMS.



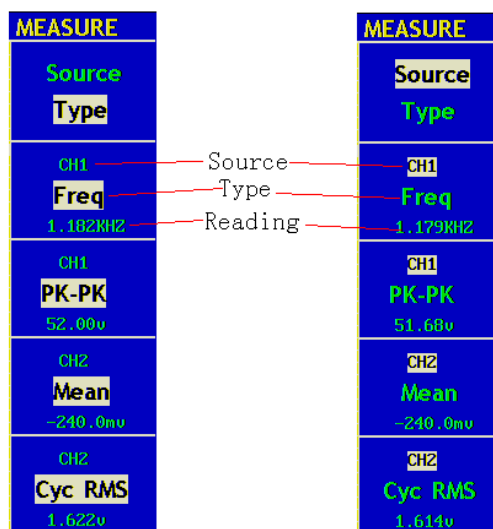


Fig.49 Measure Menu

### Term interpretation

Abbreviation	Descriptions
<b>Vpp</b>	Peak-to-Peak Voltage.
<b>Vmax</b>	The maximum amplitude. The most positive peak voltage measured over the entire waveform.
<b>Vmin</b>	The minimum amplitude. The most negative peak voltage measured over the entire waveform.
<b>Vamp</b>	Voltage between Vtop and Vbase of a waveform.
<b>Vtop</b>	Voltage of the waveform's flat top, useful for square/pulse waveforms.
<b>Vbase</b>	Voltage of the waveform's flat base, useful for square/pulse waveforms.
<b>Overshoot</b>	Defined as $(V_{max}-V_{top})/V_{amp}$ , useful for square and pulse waveforms.
<b>Preshoot</b>	Defined as $(V_{min}-V_{base})/V_{amp}$ , useful for square and pulse waveforms.
<b>Average</b>	The arithmetic mean over the entire waveform.
<b>Vrms</b>	The true Root Mean Square voltage over the entire waveform.
<b>Rise Time</b>	Time that the leading edge of the first pulse in the waveform takes to rise from 10% to 90% of its amplitude.
<b>Fall Time</b>	Time that the falling edge of the first pulse in the waveform takes to fall from 90% to 10% of its amplitude.
<b>+Width</b>	The width of the first positive pulse in 50% amplitude points.

<b>-Width</b>	The width of the first negative pulse in the 50% amplitude points.
<b>Delay 1→2</b>	The delay between the two channels at the rising edge.
<b>Delay 1→2</b>	The delay between the two channels at the falling edge.
<b>+Duty</b>	+Duty Cycle, defined as +Width/Period.
<b>-Duty</b>	-Duty Cycle, defined as -Width/Period

We now take you through an example to use Automatic measurement. Before using them, all sources of channels have to be switched on. These can be done through CH menu as mentioned before. Please be ware that this function only applies to waveform captured from input channels at YT format. It would not work on saved waveforms, calculated waveforms and waveform in XY or SCAN format. In this example, we apply square wave to Channel 1 and sine wave to Channel 2, and we want to measure the frequency, Peak-to-Peak value of Channel 1, and mean value and RMS value for Channel 2. Here is how we set them up:

- Press MEASURE to active MEASURE MENU.
- Press F1 next to Source/Type to highlight Source.
- Press F2 to choose first sources as CH1.
- Press F3 to choose second source again as CH1.
- Press F4 to choose third source as CH2.
- Press F4 to choose fourth source as CH2.
- Press F1 again to highlight Type.
- Press F2 to select Freq. A reading of 1.182Khz appears automatically.
- Press F3 to select Pk-Pk, reading appears immediately under highlighted type.
- Press F4 to select Mean for CH2, reading appears immediately.
- Press F5 to select Cyc RMS, reading appears immediately.

The measured value will be displayed in the reading window automatically (see Fig.50).

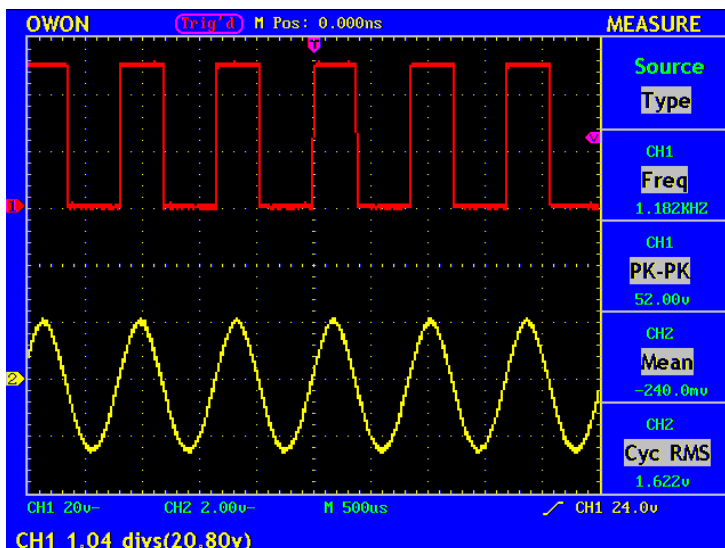


Fig.50 Automatic Measurement

### To perform the Cursor Measurement

Press **CURSOR** button on the front panel to activate cursor function menu- **CURS MEAS** on the screen, there are two types of cursors: Voltage and Time.

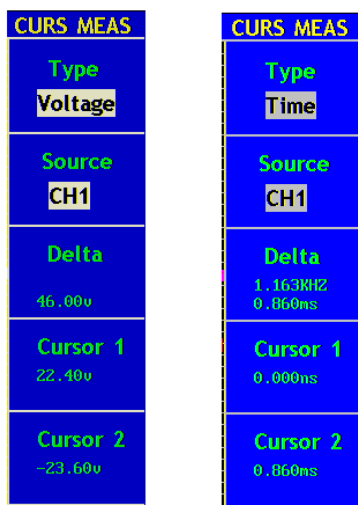


Fig.51 CURS MEAS Menu

The description of the **cursor measurement menu** is shown as the following table:

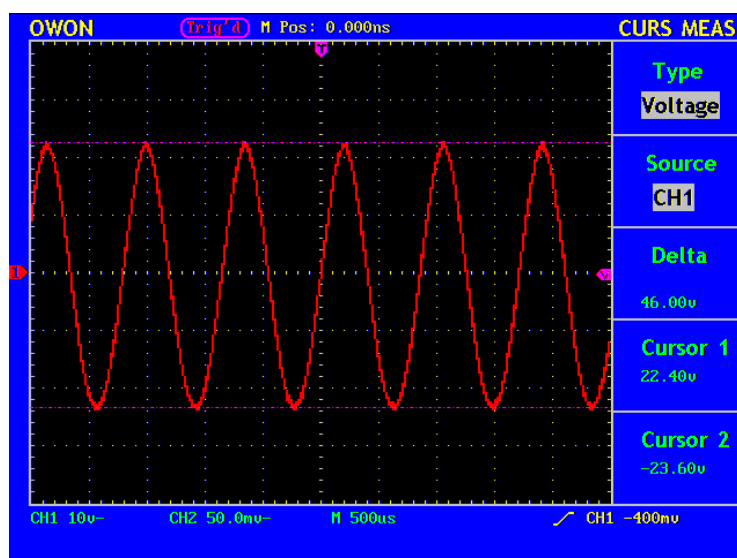
Function Menu	Setting	Description
Type	OFF	The cursor is off, no measurement taking.
	Voltage	Turn on horizontal cursors and display their voltage value.
	Time	Turn on vertical cursors and display their time value.

Source	CH1, CH2	Source signal for cursor measurement.
Delta		Absolution value of the difference between two cursors.
Cursor 1		Read the position of Cursor 1 (the Time is read with reference to the horizontal trigger position and the Voltage is to the ground point).
Cursor 2		Read the position of Cursor 1 (the Time is read with reference to the horizontal trigger position and the Voltage is to the ground point).

You can adjust the positions of Cursors by using POSITION controls, marked with CURSOR 1 and CURSOR 2. Now we take you through two examples to set up and use cursors for Voltage and Time measurements respectively. An input signal of waveform is used throughout this example.

### Voltage Cursor measurement

- Press **CURSOR** to activate **CURS MEAS** menu.
- Press **F1** to select Voltage and Type, there are two purple horizontal lines appeared on the screen, representing CURSOR 1(on the top) and CURSOR2 (on the bottom)
- Press **F2** to select **CH1** as the **Source**. The results are shown on the screen. (see Fig.52)

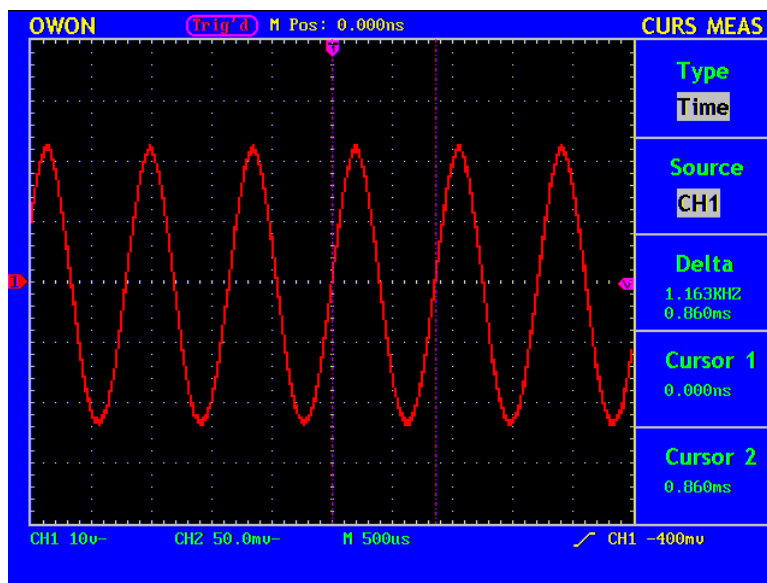


**Fig.52** Voltage Cursor Measurements

### Time Cursor measurement

- Press **CURSOR** to activate **CURS MEAS** menu.
- Press **F1** to select Time and Type, there are two purple vertical lines appeared on the screen, representing CURSOR 1(on the left) and CURSOR2 (on the right)



- Press **F2** to select **CH1** as the **Source**.
- Move **CURSOR1** and **CURSOR2** and the results change accordingly as in Fig.53.



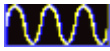

**Fig.53** Time Cursor Measurements

## Use Autoscale

This is a very useful function for first time users to carry out a simple and quick test on the input signal. It tracks the incoming signal and set up all settings to measure the signal automatically. The settings include Trigger mode, Division for voltage and Time scale based on the type of the signal, the Amplitude of signal and Frequency of the signal.

Function Menu	Setting	Instruction
Autoscale	OFF	Turn off Autoscale
	ON	Turn on Autoscale
Mode	Vertical	Only adjust vertical scale according to input signal.
	Horizontal	Only adjust horizontal scale according to input signal.
	HORI—VERT	Adjust both vertical and horizontal scales according to input signal.
Wave		Display only one or two cycles in waveform.
		Display Multi-cycles in waveform.

The function can work on both Channel 1 and Channel 2 simultaneously. Here is an example for how to use the function:

1. Press **Autoscale** to activate its menu.
2. Press **F1** next to Autoscale to select **ON**.
3. Press **F2 Mode** to select Horizontal- Vertical.
4. Press **F3** to choose  and press F3 to change to . See Fig.54/55 for details.

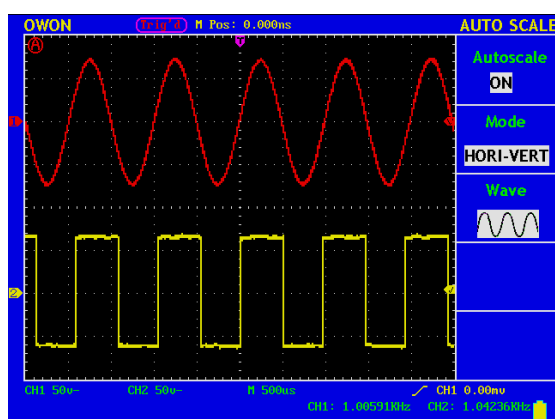


Fig.54: Multi cycles mode

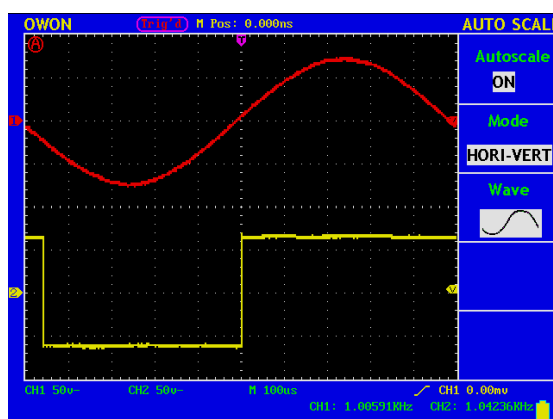



Fig.55 single cycle mode

**Note: Things you should be ware when turning on Autoscale.**

1. The symbol  is flickering on the top left corner of screen every half second.
2. The oscilloscope is setting Triggers automatically for the incoming signal based on its best approach. Access from front panel to trigger controls is disabled. A warning message will be displayed on the bottom left corner of the screen when trying to change submenus of Trigger controls.
3. If the display mode is in XY and STOP is turned on, pressing **AUTO SET** to enter into Autoscale. The oscilloscope will be set to YT mode and ATUO triggering.
4. Oscilloscope is set as DC coupling with AUTO Triggering. A warning message is displayed when trying to change these settings.
5. The oscilloscope will turn off **Autoscale** if user is trying to adjust vertical position, voltage division, trigger level or time scale for CH1 or CH2. To back to **Autoscale**, Press **AUTOSET**.
6. The oscilloscope is always on main time base.
7. The oscilloscope is turned into Peak Detection mode if it is in Average mode.
8. When video triggering, the horizontal time scale is 50us. If one channel is showing edge signal, the other channel is showing video one, the time scale refers to 50us as video one as standard.

## Use Executive controls

These controls include **AUTOSET**, **RUN/STOP**.

### AUTOSET

It's a very useful and quick way to apply a set of pre-set functions to the incoming signal, and display the best possible viewing waveform of the signal and also works out some measurement for user as well. The following table gives the details of functions applied to the signal when using **AUTOSET**.

Function Items	Setting
Acquisition Mode	Current
Vertical Coupling	DC
Vertical Scale	Adjust to the proper division.
Bandwidth	Full
Horizontal Level	Middle
Horizontal Sale	Adjust to the proper division
Trigger Type	Current
Trigger Source	Show the minimum number of channels.
Trigger Coupling	Current
Trigger Slope	Current
Trigger Level	Mid-point Setting
Trigger Mode	Auto
Display Format	YT

**RUN/STOP:** Enable or disable sampling on input signals.

#### Notes:

When there is no sampling at **STOP** state, user is still able to change vertical division or time base for waveform within a certain range. If the time base is  $\leq 50\text{ms}$ , the time base can be adjusted 4 divisions downwards.

# Quick Start Guide

## Example 1: Measuring a Simple Signal

The purpose of this example is to measure the frequency and peak-to-peak value of a given signal.

### Step 1

Go to CH1 menu and Probe menu to set attenuation coefficient as 10X, turn the switch on the Probe to 10X as well.

### Step 2

Connect the Probe through Channel 1 to the signal source.

### Step 3

Press AUTOSET button to let oscilloscope run through a pre-set functions and apply them to incoming signal.

### Step 4

Take the measurements by going through these settings.

1. Press **MEASURE** to activate measurement function menu.
2. Press **F1** next to **Source** to highlight **Source**.
3. Press **F2**, **F3**, **F4** and **F5** one by one to set them to **CH1**.
4. Press **F1** again and highlight **Type**.
5. Press **F2** and set to **Freq**.
6. Press **F3** and set to **Period**.
7. Press **F4** and set to **Mean**.
8. Press **F5** and set to **Pk-Pk**.

Now you have your measurement results displayed in Fig.56



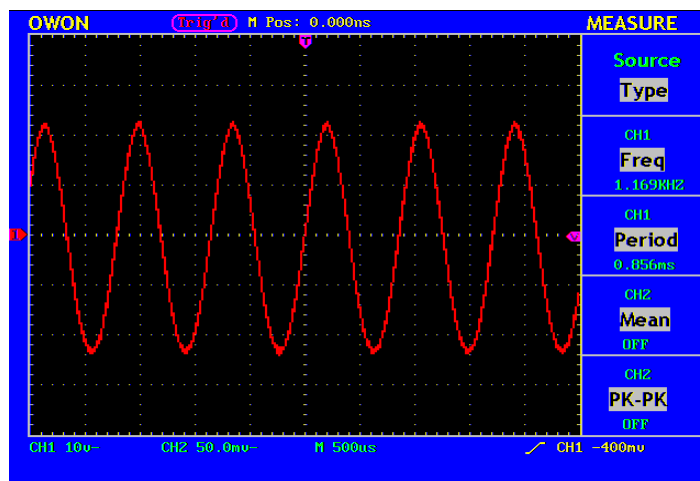


Fig.56 Measurement Frequency and PK-PK value for a given signal.

## Example 2: Working out the Gain of the Amplifier in the Metering Circuit

The purpose of this example is to work out the Gain of an Amplifier in a Metering Circuit. First we use Oscilloscope to measure the amplitude of input signal and output signal from the circuit, then to work out the Gain by using given formulas.

### Step 1

Go to both CH1 menu and CH2 menu and then their Probe menu to set attenuation coefficient as 10X, turn the switch on the Probe to 10X as well.

### Step 2

Connect the Probe through Channel 1 to the signal source the input signal in the circuit. And Probe 2 through Channel 2 to its signal source the output signal in the circuit.

### Step 3

Press AUTOSSET button to let oscilloscope run through a pre-set function and apply them to both signals coming into Channel 1 and Channel 2.

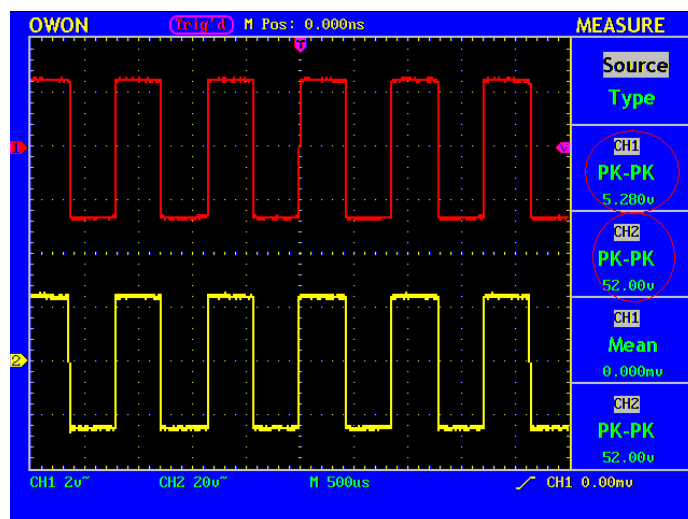
### Step 4

1. Press **MEASURE** to activate measurement function menu.
2. Press **F1** next to **Source** to highlight **Source**.
3. Press **F2** to set Source as **CH1**.
4. Press **F3** to set Source as **CH2**.
5. Press **F1** to highlight **Type**.
6. Press **F2** to set **Pk-Pk**.

7. Press **F3** to set **Pk-Pk**.
9. Get **Pk-Pk** readings of Channel 1 and Channel 2. (see Fig.57).
10. Calculate the amplifier gain with the following formulas.

$$\text{Gain} = \text{Output Signal} / \text{Input signal}$$

$$\text{Gain (db)} = 20 \times \log (\text{gain})$$



**Fig.57** Wave Form of Gain Measurement

### Example 3: Capture the Single Signal

The digital storage oscilloscope takes the lead in providing the convenience capturing of such non-periodic signals as pulse and burr, etc. If you intent to capture a single signal, you can not set the trigger level and the trigger edge unless you have particular priori knowledge of this signal. For example, if the pulse is the logic signal of a TTL level, the trigger level should be set to 2 volts and the trigger edge be set as the rising edge trigger. If it is uncertain as to the signal, you can make an observation of it in advance under the automatic or ordinary mode to determine the trigger level and the trigger edge.

**The operation steps are as follows:**

1. Set the probe menu attenuation coefficient to 10X and that of the switch in the probe to 10X.
2. Adjust the **VOLTS/DIV** and **SEC/DIV** knobs to set up a proper vertical and horizontal ranges for the signal to be observed.
3. Press the button **ACQUIRE** to display the **ACQUIRE Mode** menu.
4. Press the **F2** menu selection button and choose **Peak Detect**.
5. Press the **TRIG MENU** button to display the **Trigger Mode** menu.

6. Press the **F1** menu selection button and choose **Edge** as the trigger type.
7. Press the **F4** menu selection button and choose **Single** as the trigger mode.
8. Press the **F3** menu selection button and choose **Rising** as the slope.
9. Rotate the **LEVEL** knob and adjust the trigger level to the mid-value of the signal to be measured.
10. If the **Trigger State Indicator** at the top of the screen does not indicate **Ready**, push down the **RUN/STOP** button and start **Acquire**, waiting the emergence of the signal in conformity with the trigger conditions. If a signal reaches to the set trigger level, one sampling will be made and then displayed in the screen. With this function, any random occurrence can be captured easily. Taking the burst burr of larger amplitude for example, set the trigger level to the value just greater than the normal signal level, and then press the **RUN/STOP** button and wait. When there is a burr occurring, the instrument will trigger automatically and record the wave form generated during the period around the trigger time. With the **HORIZONTAL POSITION** knob in the horizontal control area in the panel rotated, you can change the horizontal position of the trigger position to obtain the negative delay, making an easy observation of the waveform before the burr occurs (see Fig. 58).

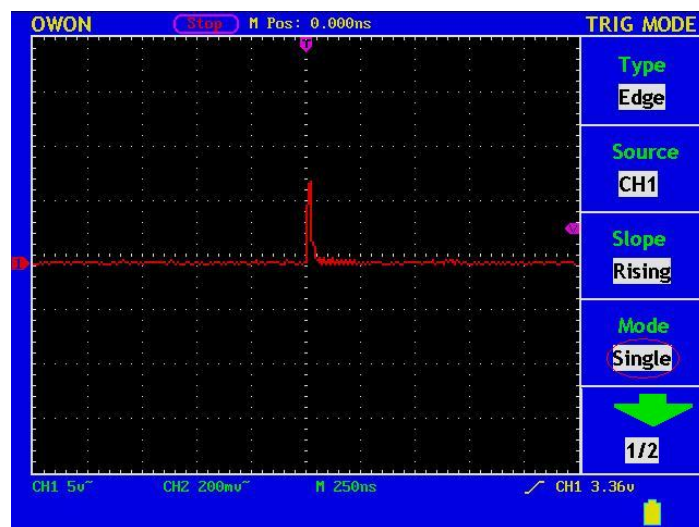


Fig. 58 Capture the Single Signal

#### Example 4: Analyze the Details of a Signal

Noise is very common inside most of the electronic signal. To find out what's inside the noise and reduce the level of noise is very important function our oscilloscope is capable to offer.

##### Noises Analysis

The level of noise sometime indicates a failure of electronic circuit. The **Peak Detect**

function acts an important role to help you to find out the details of this noise. Here is how we do it:

1. Apply Square waveform to CH1 as source signal, press **ACQUIRE** button to active **ACQU MODE** menu.
2. Press **F2** to select Peak Detect function. The signal displayed on the screen containing some noise, by turning on Peak Detect function and changing time base to slow down the incoming signal, any peaks or burr would be detected by the function. (See Fig.59).

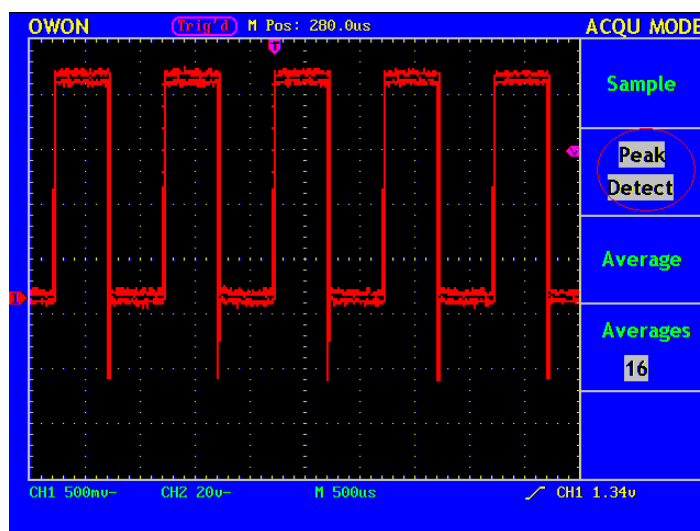


Fig.59 Signal with Noises

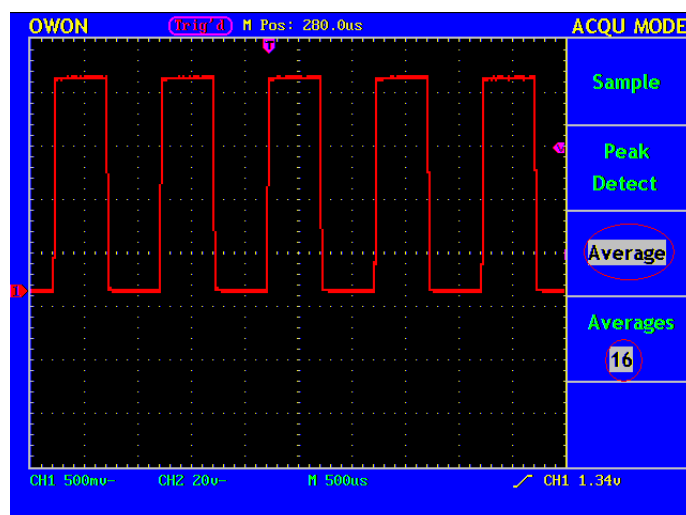
### Reduce the effect of noises from your signal

When focusing on signal itself, the important thing is to reduce the noise level as lower as possible, this would enable user to have more details about the signal. The **Average** function offered by our Oscilloscope can help you to achieve this

Here are the steps for how to enable Average function.

1. Apply square waveform to CH1 as a source signal. Press **ACQUIRE** button to bring up **ACQU MODE** menu.
2. Press **F3** selection **Average**, Press **F4** to select number of data points for average. Available choices of number are 16, 32, 64, 128. The higher the number, the better result user will get.

User would see a much reduced random noise level and make it easy to see more details of the signal itself. As it is in Fig.60, after applying Average, user can easily identify the burrs on the rising and falling edges of some part of the signal(see Fig.60).

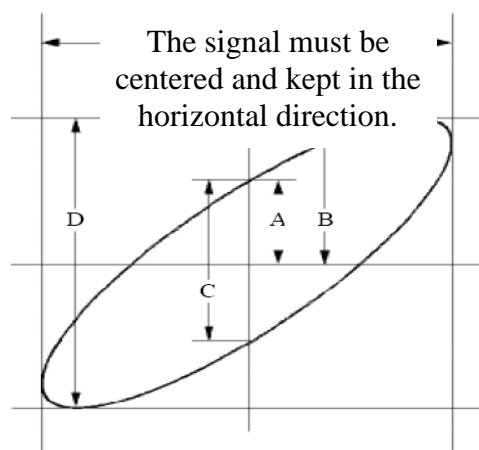


**Fig.60** Reduce Noise level by using Average function

### Example 5: Examine the Phase shift between two related signals

X-Y mode is a very useful when examining the Phase shift of two related signals. This example takes you step by step to check out the phase change of the signal after it passes a specified circuit. Input signal to the circuit and output signal from circuit are used as sources signals.

1. Set up attenuation coefficient to **10X** through Probe menu for both CH1 and CH2. Switch Probes to **10X**. For source signals, CH1 takes in input signal to the circuit and CH2 takes in output signal from circuit.
2. Press **AUTOSET**, adjust **VOLTS/DIV** for both CH1 and CH2 to the same amplitude level to get an ellipse.
3. Press **DISPLAY** to activate **DISP SET** menu, then F3 to select XY mode. Now the waveform is displayed as **Lissajou's curve**, adjust **VOLTS/DIV** and **VERTICAL POSITION** to get the best possible display, work out the phase shift as in Fig.61.



**Fig.61** Lissajous Graph

$\sin(q) = A/B$  or  $C/D$ , where  $q$  is the angle of phase shift,  $A$ ,  $B$ ,  $C$ , and  $D$  as them in Fig.69. The angle of phase shift  $q = \pm \arcsin (A/B)$  or  $\pm \arcsin (C/D)$ .

### Example 6: Video Signal Trigger

Observe the video circuit of a television, apply the video trigger and obtain the stable video output signal display.

For the trigger in the video field, carry out operations according to the following steps:

1. Press the **TRIG MENU** button to display the trigger menu.
2. Press the **F1** menu selection button and choose **Video** for Type.
3. Press the **F2** menu selection button and choose **CH1** for Source.
4. Press the **F3** menu selection button and choose **Field** for Sync.
5. Adjust the **VOLTS/DIV**, **VERTICAL POSITION** and **SEC/DIV** knobs to obtain a proper wave form display (see Fig.62).

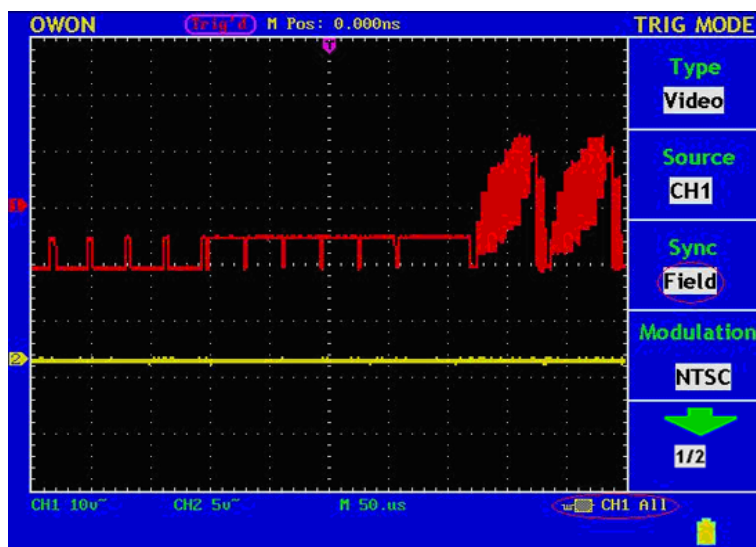


Fig. 62 Wave Form Obtained from Video Field Trigger

# Troubleshooting

- 1. In the case of that the oscilloscope is still in the black-screen state without any display after the power is switch on, perform the following Basic Troubleshooting hints procedure.**

- Check whether the power connection is connected properly.
- Check whether the power switch is pushed down to the designated position.
- Restart the instrument after be completed the checks above.
- If this product still can not work normally, please get in touch with Lilliput and we will be under your service.

- 2. After acquiring the signal, carry out the following operations if the wave form of the signal is not displayed in the screen.**

- Check whether the probe is properly connected to the signal connecting wire.
- Check whether the signal connecting wire is correctly connected to the BNC (namely, the channel connector).
- Check whether the probe is properly connected with the object to be measured.
- Check whether there is any signal generated from the object to be measured (the trouble can be shot by the connection of the channel from which there is a signal generated with the channel in fault).
- Make the signal acquisition operation again.

- 3. The measured voltage amplitude value is 10 times greater or smaller than the actual value.**

Check whether the channel attenuation coefficient and the attenuation ration of the probe used in practical application is match.

- 4. There is wave form displayed, but it is not stable.**

- Check whether the **Source** item in the **TRIG MODE** menu is in conformity with the signal channel used in the practical application.
- Check on the trigger **Type** item: The common signal chooses the **Edge** trigger mode for **Type** and the video signal the **Video**. Only if a proper trigger mode is applied, the wave form can be displayed steadily.
- Try to change the trigger coupling into the high frequency suppress and the low frequency suppress to smooth the high frequency or low frequency noise triggered by the interference.

- 5. No Display Responses to the Push-down of RUN/STOP.**

Check whether Normal or Signal is chosen for Polarity in the TRIG MODE menu and the trigger level exceeds the wave form range.

If it is, make the trigger level is centered in the screen or set the trigger mode as Auto. In addition, with the **AUTOSET** button pressed, the setting above can be completed automatically.

- 6. After the AVERAGE value sampling is set in the ACQU MODE or a longer duration is set in the DISP MODE, the display rate is slowed down.**

It is a normal phenomenon.

## Appendix A: Technical Specifications

Unless otherwise specified, the technical specifications applied are applicable to the probe with the attenuation switch setting 10X and the PDS series digital oscilloscope. Only if the oscilloscope fulfill the following two conditions at first, can these specification standards be reached.

- This instrument should run for more than 30 minutes continuously under the specified operating temperature.
- If the change range of the operating temperature is up to or exceeds 5 °C, open the system function menu and execute the “Self-calibration” procedure.

All specification standards can be fulfilled, except one(s) marked with the word “Typical”.

Characteristic		Instruction
Bandwidth		<ul style="list-style-type: none"> <li>●25MHz ---- PDS5022S/T</li> <li>●40MHz ---- PDS6042S</li> <li>●60MHz ---- PDS6062S</li> </ul>
Channel		2 + 1 (External)
Acquisition:	Mode	Normal, Peak detect, Averaging
	Sample rate (real time)	<ul style="list-style-type: none"> <li>●100MS/s ---- PDS5022S/T</li> <li>●250MS/s --- PDS6042S, PDS6062S</li> </ul>
Input:	Input coupling	DC, AC, Ground
	Input impedance	●1MΩ±2%, in parallel with 20pF±5pF
	Probe attenuation factor	1X, 10X, 100X, 1000X
	Max. input voltage	300V (PK-PK) (DC + AC PK-PK)
Horizontal System:	Sampling rate	<ul style="list-style-type: none"> <li>●10S/s~100MS/s---- PDS5022S/T</li> <li>●10S/s~250MS/s---- PDS6042S, PDS6062S</li> </ul>
	Interpolation	(sin x) /x
	Record length	<ul style="list-style-type: none"> <li>● 5K points on each channel---- PDS5022S/T</li> <li>● 6K points on each channel ---- PDS6042S, PDS6062S</li> </ul>
	Scanning speed (S/div)	5ns/div~100s/div, <ul style="list-style-type: none"> <li>●step by 1~2.5~5 ---- PDS5022S/T</li> <li>●step by 1~2~5--- PDS6042S, PDS6062S</li> </ul>



	Sampling rate / relay time accuracy		$\pm 100\text{ppm}$
	Interval ( $\Delta T$ ) accuracy (DC~100MHz)		Single: $\pm(1 \text{ interval time} + 100\text{ppm} \times \text{reading} + 0.6\text{ns})$ Average > 16: $\pm(1 \text{ interval time} + 100\text{ppm} \times \text{reading} + 0.4\text{ns})$
<b>Vertical system:</b>	A/D converter		8 bits resolution (2 Channels simultaneously)
	Sensitivity		5mV/div~5V/div (at input)
	Displacement		• $\pm 10\text{div}(5\text{mV/div} \sim 5\text{V/div})$ ----PDS5022S/T • $\pm 50\text{V}(500\text{mV} \sim 5\text{V}), \pm 2\text{V}(5\text{mV} \sim 200\text{mV})$ ---- PDS6042S, PDS6062S
	Single bandwidth		Full bandwidth
	Low Frequency		$\geq 10\text{Hz}$ (at input, AC coupling, -3dB)
	Rise time (at input, Typical)		$\leq 14\text{ns}$ ----PDS5022S/T $\leq 8.75\text{ns}$ ---- PDS6042S $\leq 5.8\text{ns}$ ---- PDS6062S
	DC accuracy		$\pm 3\%$
	DC accuracy (average)		The voltage difference (points on the wave form after averaging the captured wave forms of more than 16: $\pm (5\% \text{ Reading} + 0.05 \text{ divisions})$ )
<b>Trigger</b>	Type	Edge	Rising、Falling
		Video	Line synchronization, Field synchronization, Odd field, Even field, Any line
	Edge trigger	Sensitivity	Adjustable: 0.2div~1.0div
	Coupling	DC, AC, LF Rjc, HF Rjc	
	Trigger level	Internal	$\pm 6 \text{ div}$ from the screen center
EXT		$\pm 600\text{mV}$	

	range	EXT/5	$\pm 3V$
	Trigger	Internal	$\pm 0.3\text{div}$
	level	EXT	$\pm(40\text{mV} + 6\% \text{ of Set Value})$
	Accuracy (typical) :	EXT/5	$\pm(200\text{mV} + 6\% \text{ of Set Value})$
	Horizontal Trigger displacement		Pre-trigger : 655 div Post-trigger : 4 div
	Trigger Holdoff range		100ns~10s
	50% level setting (typical)		Input signal frequency $\geq 50\text{Hz}$
	Trigger sensitivity (Video trigger, typical)	Internal	Peak-peak value of 2div
		EXT	400mV
		EXT/5	2V
	Signal system		NTSC, PAL, SECAM (any frequency)
	Alternate trigger	CH1 trigger	Edge, Video
		CH2 trigger	Edge, Video
<b>Measurement</b>	Cursor		$\Delta V$ and $\Delta T$ between cursors
	Automatic		Peak-to-peak value, average value, root mean square value, frequency, period, $V_{\text{max}}$ , $V_{\text{min}}$ , $V_{\text{top}}$ , $V_{\text{base}}$ , $V_{\text{amp}}$ , Overshoot, Preshoot, RiseTime, Fall Time, $+Width$ , $-Width$ , $+Duty$ , $-Duty$ , $\text{DelayA} \rightarrow \text{B}$ and $\text{DelayA} \rightarrow \text{B}$
	Waveform Math		$+$ , $-$ , Invert, FFT
	Waveform storage		4 waveforms
	Lissajou's figure	Bandwidth	Full bandwidth
		Phase difference	$\pm 3$ degrees
Communication port	USB1.1 or RS-232		

## General Specifications

### Display

Model	PDS5022S, PDS6042S, PDS6062S	PDS5022T
Display Type	7.5" color liquid crystal display	8" color liquid crystal display
Display Color	256 colors	65536 colors, TFT screen
Display Resolution	640 (horizontal) × 480 (vertical) pixels	

### Probe compensation

Output voltage (typical)	5V, with the Peak-to-peak value $\geq 1M\Omega$
Frequency ( typical)	1KHz square wave

### Power

Supply	100-240 VACRMS, 50/60Hz, CAT II
Consumption	<15W
Fuse	2A, T class, 250V
Battery	Optional

### Environment

Temperature	Working temperature: 0 ℃ ~ 40 ℃ Storage temperature: -20 ℃ ~ +60 ℃
Relative Humidity	≤ 90%
Height	Operating: 3,000 m Non-operating: 15,000 m
Cooling Method	Natural convection

### Mechanical Specifications

Model	PDS5022S/T	PDS6042S PDS6062S
Weight	1.6kg	1.7kg
Dimension	350mm×157mm× 103mm	

Manufacturer reserves the right to change the specification at anytime without prior notice.

**Interval Period of calibration:**

## **CALIBRATION**

Perform self- calibration to verify that your instrument is operating properly. Self-calibration performs an internal self- alignment routine to optimize the signal path in the oscilloscope. The routine uses internally generated signals to optimize circuits that affect channel sensitivity, offset and trigger parameters. Let the instrument to warm up for at least 30 minutes before performing self- calibration. You should perform self- calibration according to the following recommendations:

- Every 12 months or after 2000 hours of operation
- If the ambient temperature is  $> 10$  °C from the calibration temperature
- If you want to maximize the measurement accuracy
- After experiencing abnormal operation.
- To verify proper operation after repairing

## Appendix B: Package Contents

### Standard Accessories:

- Passive probe: x 2,
- CD: x 1 (PC link application software).
- RS232 data line or USB data line: x 1
- Power line: x 1 (up to the standards of the country in which it is used.)
- User Manual: x 1

### Options:

- Battery

## Appendix C: Maintenance, Cleaning and Repairing

### General Maintenance

Please don't store or put the instrument in the place where the liquid crystal display will be directly exposed to the sunlight for a long time.

**Caution:** The instrument or probe should not be stained with the spraying agent, liquid and solvent to avoid any damage to it.

### Cleaning

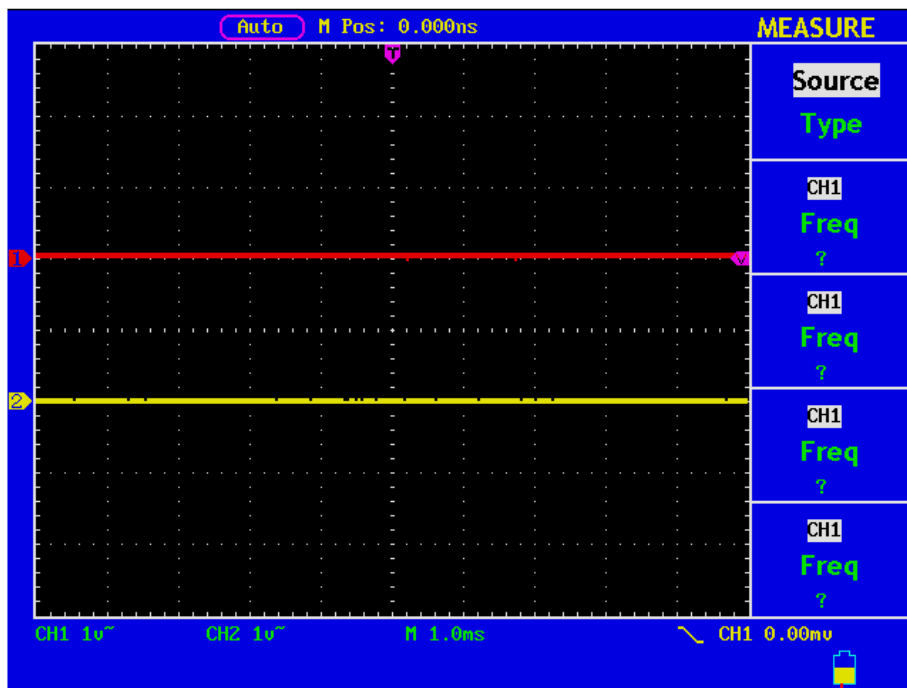
Check the probe and instrument regularly according to their operating state. Clean the external surface of the instrument following the steps what shown as below:

1. Please wipe the dust from the instrument and probe surface with a soft cloth. Do not make any scuffing on the transparent LCD protection screen when clean the LCD screen.
2. Clean the instrument with a wet soft cloth not dripping water, during the period of which please pay attention to the disconnection of power. It is recommended to scrub with soft detergent or fresh water. Please don't apply any corrosive chemical cleaning agent to prevent the instrument or probe from damage.



**Warn:** Before power on again for operation, it is required to confirm that the instrument has already been dried completely, avoiding any electrical short circuit or bodily injury resulting from the moisture.

# Appendix D: Battery Using Guide



Battery electric quantity indicating symbols including: and

### Charging the oscilloscope

The lithium battery maybe not be charged when delivery. Please charge the battery for 12 hours to make sure enough power to supply (the oscilloscope should be turned on during charging) to oscilloscope. The battery can supply power for 4 hours after being charged completely.

There will have battery power indication show on the top of panel when oscilloscope power supplied by the battery. and imply for different power consumption and when shows it means the power can only supply for 5 minutes maximum.

### Note:

To avoid superheat of battery during charging, the environment temperature is not allowed to exceed the permissible value given in technical specification.

### Replacing the Lithium Battery Unit

It is usually not required to replace the battery unit. But when it is required to replace it, only qualified personnel can carry out this operation, and only use the same specification lithium battery.